

 **ARAS**   
**SOĞUTMA**  
**AYAKKABI GIDA OT. SAN.TİC.LTD.ŞTİ**

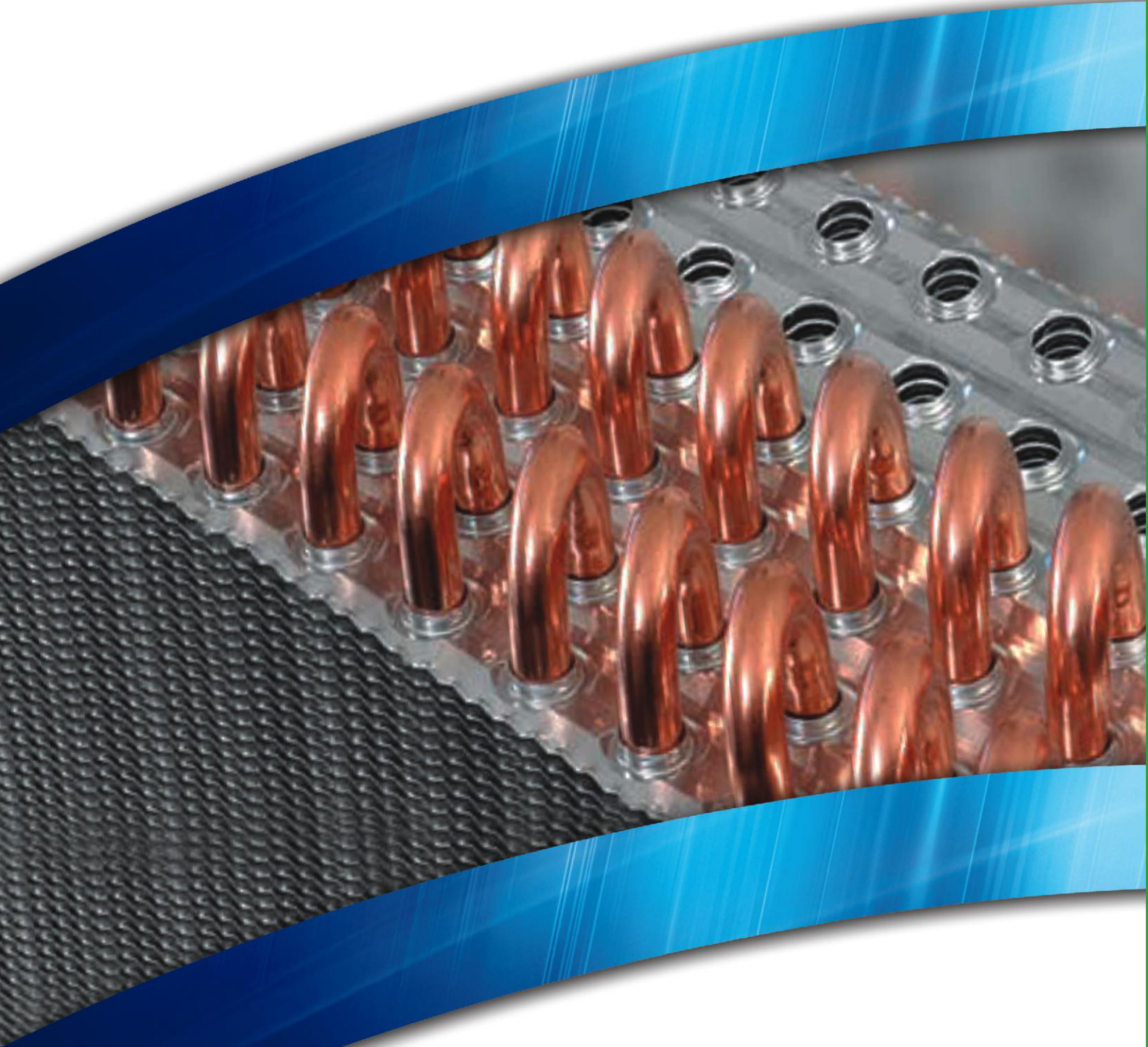

**EKİM 2014 FİYAT LİSTESİ**  
**OCTOBER 2014 PRICE LIST**





## FİRMA PROFİLİ

Firmamız Yılmaz ARAS tarafından 1998 yılında kurulmuş ve İstanbul'da Soğutma Sektöründe hizmet vermeye başlamıştır. Firmamız ilerleyen yıllarda pastane dolapları, market dolapları, hastane morgları, soğuk hava depoları, çiğ köfte dolapları v.b. ürünlerle hizmet verip, her türlü imalat - montaj - servis - bakım - onarım yapmaktadır.

Bilgi birikimini artırarak büyümeye devam eden Aras Soğutma, 2014 yılında, market evaporatörleri, hava soğutmalı kondanselerler, soğuk oda evaporatörleri, sıcak - soğuk su ve buhar bataryaları, yağ soğutucuları imalatına başlamış olup, ayrıca firmaların isteklerine göre özel kondanser ve evaporatörleri üreten teknik donanımlı bir şirket haline gelmiştir.

Merkezi İstanbul Kirazlı / Bağcılar olan ARAS SOĞUTMA, modern ve yeni makine parkı, donanımı ve uzman çalışanları ile hem yurtiçi hem de yurtdışı soğutma sektörüne hizmet vermektedir.

Maliyet, kalite, minimum termin süreleri ve müşteri memnuniyetini en ön planda tutan şirketimiz ayrıca ısı ve enerji verimliliğini, çevrenin korunmasını, şeffaf bir satış sürecini benimseyerek hareket etmektedir. ARAS SOĞUTMA şirketimiz hızlı büyüme, yüksek sayıda ve nitelikli kalifiye istihdam sağlama gayesindedir.

## COMPANY PROFILE

*Our company ARAS COOLING, was established by Yılmaz ARAS in 1998 and began to operate in the refrigeration sector in İstanbul. In later years, our company expanded its portfolio with such products as bakery cabinets, market cabinets, hospital morgues and cold storage cabinets while providing various services including manufacturing, installation, maintenance and repair.*

*In 2014, Aras Cooling, continuing its growth by increasing company's know-how, starts production of market evaporators, air cooled condensers, cold room evaporators, water-steam heaters and coolers, oil coolers and special condensers and also evaporators designed according to the demands of our customers.*

*Headquarters building located in İstanbul Kirazlı / Bağcılar area, ARAS COOLING provides services in domestic and international refrigeration market with its high-qualified expert staff and state of the art production technologies.*

*While transparent sales processes, cost, quality, speed and customer satisfaction being primary performance indices, our company also highly values and considers heat and energy efficiency and environmental protection. We also aim a rapid sustainable growth while providing numerous job opportunities to a large group of qualified personnel.*

## GENEL ŞARTLAR VE TİCARİ KOŞULLAR

- Fiyatlarımıza KDV dahil Değildir.
- Fatura tarihindeki TCMB efektif döviz satış kuru geçerlidir.
- Listemizdeki fiyatları ve satış koşullarını önceden haber vermeksizin değiştirme hakkımız saklıdır
- Vadesini geçen ödemeler için günün şartlarındaki kredi oranı yüzdelerinde vade farkı uygulanır.
- Fiyatlarımız Aras Soğutma İstanbul Fabrika teslimidir. Her türlü sigorta ve nakliye alıcıya aittir.
- Ürünler galvaniz saçlı olarak imal edilirler.
- Ürünlerin elektrostatik toz boyalı istenmesi halinde ( Soğuk Oda Evaporatörleri hariç)  
Listede boyalı olarak belirtilmemişse ticari serilerde % 7 fiyat farkı ilave edilir
- Standart boya rengi Ral 7035 'dir.
- Epoksi kaplı lamel kullanılarak üretilen ürünlerde % 10 fiyat farkı uygulanır
- Paslanmaz saç kullanılarak üretilen ürünlerde % 40 fiyat farkı uygulanır.
- Aksiyal Fan motorları istek halinde ayrıca fiyatlandırılarak ürün üzerine monte edilebilir.
- Ürünlerimizle ilgili teknik açıklama ve daha detaylı bilgi almak için lütfen bizimle irtibata geçiniz.
- Listemizde yer almayan diğer ürünler için satış birimimizle görüşünüz.
- İskonto oranları için lütfen firmamızla irtibata geçiniz
  
- Siparişlerinizi bekler hayırlı işler dileriz.

### **ARAS SOĞUTMA GIDA OTOMOTİV SAN.TİC.LTD.ŞTİ**

BANKA ADI : YAPI KREDİ BANKASI

IBAN (TL) : TR46 0006 7010 0000 0091 7022 94

### **SERVET ARAS**

BANKA ADI : YAPI KREDİ BANKASI

IBAN (TL) : TR04 0006 7010 0000 0071 7417 11

### **ARAS SOĞUTMA GIDA OTOMOTİV SAN.TİC.LTD.ŞTİ**

BANKA ADI : AKBANK

IBAN (TL) : TR79 0004 6004 4788 800 0023 89



MARKET SOĞUTUCULAR / YAN SOĞUTUCULAR

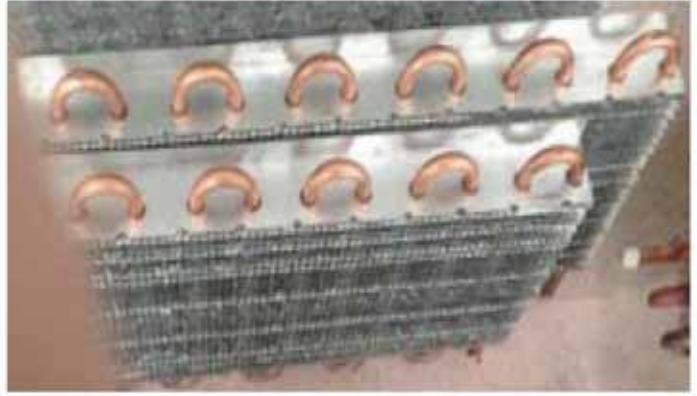

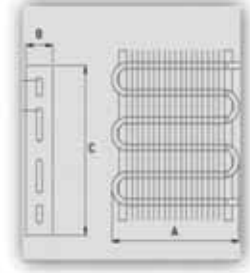
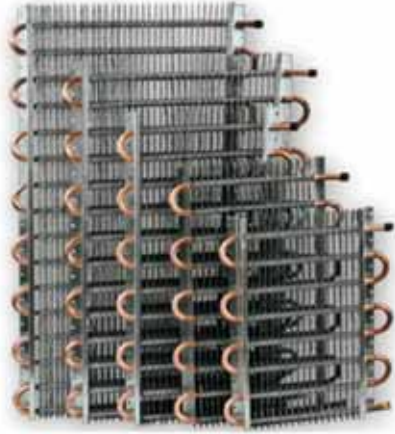

### ARYS SERİSİ TEKLİ YAN SOĞUTUCULAR ARYS SERIES SINGLE-ROW SIDE COLLERS

Lamel Aralığı Fin Spacing	KOD CODE	MODEL MODEL	Yüzey Surface	Kapasite Capacity (R 404 A)		Boyutlar Dimension			Fiyat Price  €
				Watt	kcal/h	A	B	C	
			m <sup>2</sup>	mm	mm	mm	mm		
<b>5648-1/2"</b>									
12 mm	ARYS 35.4	2'li Yan 35x4	0,45	38	33	350	65	225	6,81 €
	ARYS 40.4	2'li Yan 40x4	0,54	46	40	400			7,78 €
	ARYS 45.4	2'li Yan 45x4	0,63	54	46	450			8,75 €
	ARYS 50.4	2'li Yan 50x4	0,72	62	53	500			9,72 €
	ARYS 55.4	2'li Yan 55x4	0,81	69	59	550			10,69 €
	ARYS 60.4	2'li Yan 60x4	0,91	77	66	600			11,67 €
12 mm	ARYS 35.6	3'lü Yan 35x6	0,68	58	50	350	65	337	10,21 €
	ARYS 40.6	3'lü Yan 40x6	0,81	69	59	400			11,67 €
	ARYS 45.6	3'lü Yan 45x6	0,95	81	69	450			13,13 €
	ARYS 50.6	3'lü Yan 50x6	1,09	92	79	500			14,58 €
	ARYS 55.6	3'lü Yan 55x6	1,22	104	89	550			16,04 €
	ARYS 60.6	3'lü Yan 60x6	1,36	115	99	600			17,50 €
12 mm	ARYS 35.8	4'lü Yan 35x8	0,91	77	66	350	65	449	13,61 €
	ARYS 40.8	4'lü Yan 40x8	1,09	92	79	400			15,56 €
	ARYS 45.8	4'lü Yan 45x8	1,27	108	93	450			17,50 €
	ARYS 50.8	4'lü Yan 50x8	1,45	123	106	500			19,44 €
	ARYS 55.8	4'lü Yan 55x8	1,63	139	119	550			21,39 €
	ARYS 60.8	4'lü Yan 60x8	1,81	154	132	600			23,33 €
12 mm	ARYS 35.10	5'li Yan 35x10	1,13	96	83	350	65	570	17,01 €
	ARYS 40.10	5'li Yan 40x10	1,36	115	99	400			19,44 €
	ARYS 45.10	5'li Yan 45x10	1,58	135	116	450			21,88 €
	ARYS 50.10	5'li Yan 50x10	1,81	154	132	500			24,31 €
	ARYS 55.10	5'li Yan 55x10	2,04	173	149	550			26,74 €
	ARYS 60.10	5'li Yan 60x10	2,26	192	165	600			29,17 €
12 mm	ARYS 35.12	6'lı Yan 35x12	1,36	115	99	350	65	673	20,42 €
	ARYS 40.12	6'lı Yan 40x12	1,63	139	119	400			23,33 €
	ARYS 45.12	6'lı Yan 45x12	1,90	162	139	450			26,25 €
	ARYS 50.12	6'lı Yan 50x12	2,17	185	159	500			29,17 €
	ARYS 55.12	6'lı Yan 55x12	2,44	208	178	550			32,08 €
	ARYS 60.12	6'lı Yan 60x12	2,72	231	198	600			35,00 €

\* ARYS 1/2" TEKLİ YAN SOĞUTUCULAR Metre Fiyatları 4,87 €



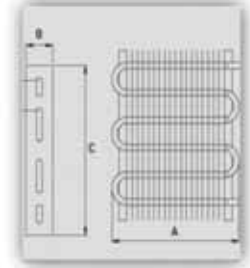
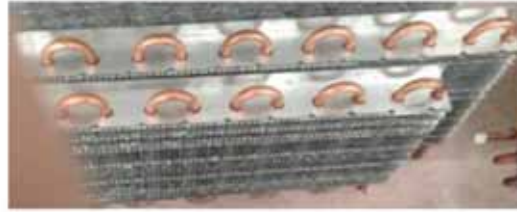
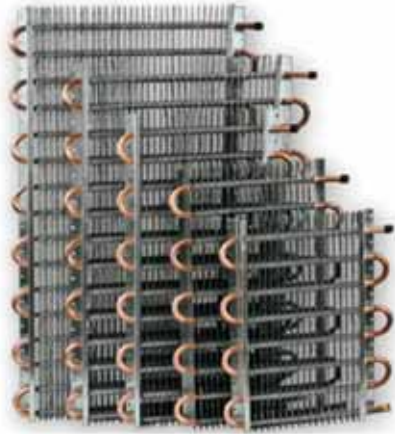

### ARYS SERİSİ TEKLİ YAN SOĞUTUCULAR ARYS SERIES SINGLE-ROW SIDE COLLERS

Lamel Aralığı Fin Spacing	KOD CODE	MODEL MODEL	Yüzey Surface m <sup>2</sup>	Kapasite Capacity (R 404 A)		Boyutlar Dimension			Fiyat Price €
				Watt	kcal/h	A mm	B mm	C mm	
<b>5648-1/2"</b>									
12 mm	ARYS 35.14	7'li Yan 35x14	1,58	135	116	350	65	785	23,82 €
	ARYS 40.14	7'li Yan 40x14	1,90	162	139	400			27,22 €
	ARYS 45.14	7'li Yan 45x14	2,22	189	162	450			30,63 €
	ARYS 50.14	7'li Yan 50x14	2,53	215	185	500			34,03 €
	ARYS 55.14	7'li Yan 55x14	2,85	242	208	550			37,43 €
	ARYS 60.14	7'li Yan 60x14	3,17	269	231	600			40,83 €
12 mm	ARYS 35.16	8'li Yan 35x16	1,81	154	132	350	65	897	27,22 €
	ARYS 40.16	8'li Yan 40x16	2,17	185	159	400			31,11 €
	ARYS 45.16	8'li Yan 45x16	2,53	215	185	450			35,00 €
	ARYS 50.16	8'li Yan 50x16	2,90	246	212	500			38,89 €
	ARYS 55.16	8'li Yan 55x16	3,26	277	238	550			42,78 €
	ARYS 60.16	8'li Yan 60x16	3,62	308	264	600			46,67 €
12 mm	ARYS 35.18	9'lu Yan 35x18	2,04	173	149	350	65	1009	30,63 €
	ARYS 40.18	9'lu Yan 40x18	2,44	208	178	400			35,00 €
	ARYS 45.18	9'lu Yan 45x18	2,85	242	208	450			39,38 €
	ARYS 50.18	9'lu Yan 50x18	3,26	277	238	500			43,75 €
	ARYS 55.18	9'lu Yan 55x18	3,67	312	268	550			48,13 €
	ARYS 60.18	9'lu Yan 60x18	4,07	346	297	600			52,50 €
12 mm	ARYS 35.20	10'lu Yan 35x20	2,26	192	165	350	65	1130	34,03 €
	ARYS 40.20	10'lu Yan 40x20	2,72	231	198	400			38,89 €
	ARYS 45.20	10'lu Yan 45x20	3,17	269	231	450			43,75 €
	ARYS 50.20	10'lu Yan 50x20	3,62	308	264	500			48,61 €
	ARYS 55.20	10'lu Yan 55x20	4,07	346	297	550			53,47 €
	ARYS 60.20	10'lu Yan 60x20	4,53	385	331	600			58,33 €

\* ARYS 1/2" TEKLİ YAN SOĞUTUCULAR Metre Fiyatları 4,87 €

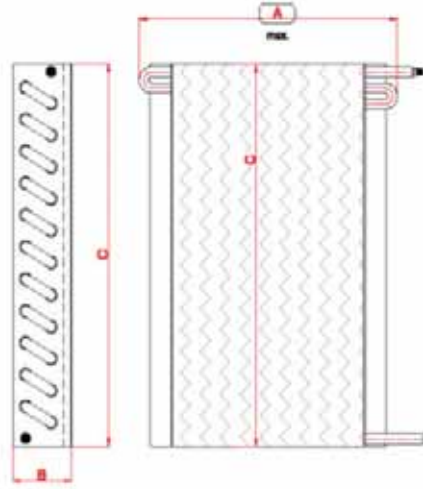
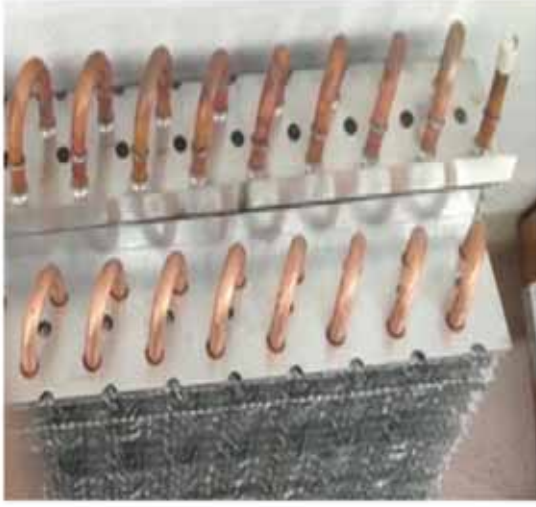

### ARYS SERİSİ DOUBLE ÇİFTLİ YAN SOĞUTUCULAR ARYS SERIES DOUBLE-ROW SIDE COLLERS

Lamel Aralığı Fin Spacing	KOD CODE	MODEL MODEL	Yüzey Surface	Kapasite Capacity (R 404 A)		Boyutlar Dimension			Fiyat Price  €
				m <sup>2</sup>	Watt	kcal/h	A mm	B mm	
<b>5648-1/2"</b>									
12 mm	ARYS 35.4.2	2'li Yan 35x4	0,91	77	66	350	110	225	13,61 €
	ARYS 40.4.2	2'li Yan 40x4	1,09	92	79	400			15,56 €
	ARYS 45.4.2	2'li Yan 45x4	1,27	108	93	450			17,50 €
	ARYS 50.4.2	2'li Yan 50x4	1,45	123	106	500			19,44 €
	ARYS 55.4.2	2'li Yan 55x4	1,63	139	119	550			21,39 €
	ARYS 60.4.2	2'li Yan 60x4	1,81	154	132	600			23,33 €
12 mm	ARYS 35.6.2	2'li Yan 35x6	1,36	115	99	350	110	337	20,42 €
	ARYS 40.6.2	2'li Yan 40x6	1,63	139	119	400			23,33 €
	ARYS 45.6.2	2'li Yan 45x6	1,90	162	139	450			26,25 €
	ARYS 50.6.2	2'li Yan 50x6	2,17	185	159	500			29,17 €
	ARYS 55.6.2	2'li Yan 55x6	2,44	208	178	550			32,08 €
	ARYS 60.6.2	2'li Yan 60x6	2,72	231	198	600			35,00 €
12 mm	ARYS 35.8.2	2'li Yan 35x8	1,81	154	132	350	110	449	27,22 €
	ARYS 40.8.2	2'li Yan 40x8	2,17	185	159	400			31,11 €
	ARYS 45.8.2	2'li Yan 45x8	2,53	215	185	450			35,00 €
	ARYS 50.8.2	2'li Yan 50x8	2,90	246	212	500			38,89 €
	ARYS 55.8.2	2'li Yan 55x8	3,26	277	238	550			42,78 €
	ARYS 60.8.2	2'li Yan 60x8	3,62	308	264	600			46,67 €
12 mm	ARYS 35.10.2	2'li Yan 35x10	2,26	192	165	350	110	570	34,03 €
	ARYS 40.10.2	2'li Yan 40x10	2,72	231	198	400			38,89 €
	ARYS 45.10.2	2'li Yan 45x10	3,17	269	231	450			43,75 €
	ARYS 50.10.2	2'li Yan 50x10	3,62	308	264	500			48,61 €
	ARYS 55.10.2	2'li Yan 55x10	4,07	346	297	550			53,47 €
	ARYS 60.10.2	2'li Yan 60x10	4,53	385	331	600			58,33 €
12 mm	ARYS 35.12.2	2'li Yan 35x12	2,72	231	198	350	110	673	40,83 €
	ARYS 40.12.2	2'li Yan 40x12	3,26	277	238	400			46,67 €
	ARYS 45.12.2	2'li Yan 45x12	3,80	323	278	450			52,50 €
	ARYS 50.12.2	2'li Yan 50x12	4,35	369	317	500			58,33 €
	ARYS 55.12.2	2'li Yan 55x12	4,89	416	357	550			64,17 €
	ARYS 60.12.2	2'li Yan 60x12	5,43	462	397	600			70,00 €

\* ARYS 1/2" ÇİFTLİ YAN SOĞUTUCULAR Metre Fiyatları 4,87 €

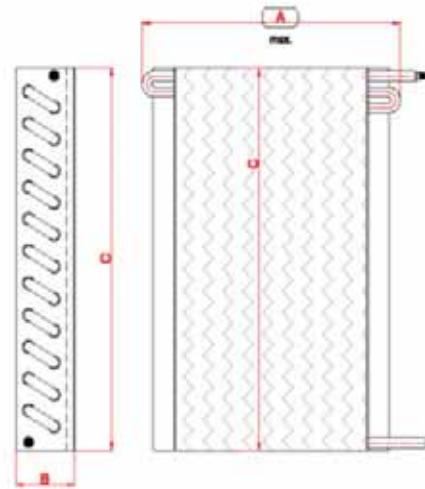
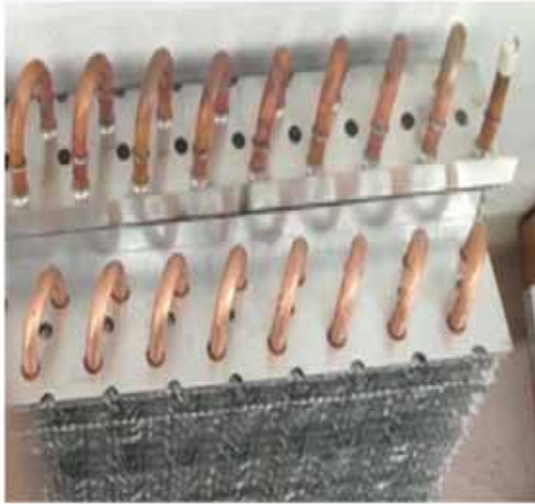

### ARYS SERİSİ ÇİFTLİ YAN SOĞUTUCULAR ARYS SERIES DOUBLE-ROW SIDE COLLERS

Lamel Aralığı Fin Spacing	KOD CODE	MODEL MODEL	Yüzey Surface	Kapasite Capacity (R 404 A)		Boyutlar Dimension			Fiyat Price  €
				m <sup>2</sup>	Watt	kcal/h	A mm	B mm	
<b>5648-1/2"</b>									
12 mm	ARYS 35.14.2	2'li Yan 35x14	3,17	269	231	350	110	785	47,64 €
	ARYS 40.14.2	2'li Yan 40x14	3,80	323	278	400			54,44 €
	ARYS 45.14.2	2'li Yan 45x14	4,44	377	324	450			61,25 €
	ARYS 50.14.2	2'li Yan 50x14	5,07	431	370	500			68,06 €
	ARYS 55.14.2	2'li Yan 55x14	5,70	485	416	550			74,86 €
	ARYS 60.14.2	2'li Yan 60x14	6,34	539	463	600			81,67 €
12 mm	ARYS 35.16.2	2'li Yan 35x16	3,62	308	264	350	110	897	54,44 €
	ARYS 40.16.2	2'li Yan 40x16	4,35	369	317	400			62,22 €
	ARYS 45.16.2	2'li Yan 45x16	5,07	431	370	450			70,00 €
	ARYS 50.16.2	2'li Yan 50x16	5,79	493	423	500			77,78 €
	ARYS 55.16.2	2'li Yan 55x16	6,52	554	476	550			85,56 €
	ARYS 60.16.2	2'li Yan 60x16	7,24	616	529	600			93,33 €
12 mm	ARYS 35.18.2	2'li Yan 35x18	4,07	346	297	350	110	1009	61,25 €
	ARYS 40.18.2	2'li Yan 40x18	4,89	416	357	400			70,00 €
	ARYS 45.18.2	2'li Yan 45x18	5,70	485	416	450			78,75 €
	ARYS 50.18.2	2'li Yan 50x18	6,52	554	476	500			87,50 €
	ARYS 55.18.2	2'li Yan 55x18	7,33	623	535	550			96,25 €
	ARYS 60.18.2	2'li Yan 60x18	8,15	693	595	600			105,00 €
12 mm	ARYS 35.20.2	2'li Yan 35x20	4,53	385	331	350	110	1130	68,06 €
	ARYS 40.20.2	2'li Yan 40x20	5,43	462	397	400			77,78 €
	ARYS 45.20.2	2'li Yan 45x20	6,34	539	463	450			87,50 €
	ARYS 50.20.2	2'li Yan 50x20	7,24	616	529	500			97,22 €
	ARYS 55.20.2	2'li Yan 55x20	8,15	693	595	550			106,94 €
	ARYS 60.20.2	2'li Yan 60x20	9,05	770	661	600			116,67 €

\* ARYS 1/2" ÇİFTLİ YAN SOĞUTUCULAR Metre Fiyatları 4,87 €

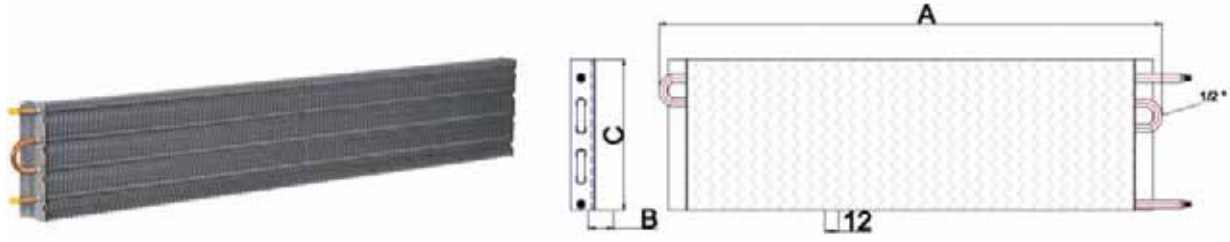

**ARMAE SERİSİ MARKET ALT EVAPORATÖR**  
ARMAE SERIES COLLERS BELOW FOR SHOP WINDOWS

Lamel Aralığı Fin Spacing	KOD CODE	MODEL MODEL	Isı Transfer Alanı Heat Transfer Area	Kapasite Capacity (R 404 A)		Boyutlar Dimension			Fiyat Price
						A	B	C	
						m <sup>2</sup>	Watt	kcal/h	

5648-1/2"									
12 mm	ARMAE 75.3	75 Cm 3'lü	0,88	75	64	750	55	168	10,94 €
	ARMAE 100.3	100 Cm 3'lü	1,22	104	89	1.000			14,58 €
	ARMAE 120.3	120 Cm 3'lü	1,49	127	109	750			17,50 €
	ARMAE 150.3	150 Cm 3'lü	1,90	162	139	1.500			21,88 €
	ARMAE 170.3	170 Cm 3'lü	2,17	185	159	1.700			24,79 €
	ARMAE 200.3	200 Cm 3'lü	2,58	219	188	2.000			29,17 €
	ARMAE 220.3	220 Cm 3'lü	2,85	242	208	2.200			32,08 €
	ARMAE 250.3	250 Cm 3'lü	3,26	277	238	2.500			36,46 €
	ARMAE 270.3	270 Cm 3'lü	3,53	300	258	2.700			39,38 €
ARMAE 300.3	300 Cm 3'lü	3,94	335	288	3.000	43,75 €			

12 mm	ARMAE 75.4	75 Cm 4'lü	1,18	100	86	750	55	224	14,58 €
	ARMAE 100.4	100 Cm 4'lü	1,63	139	119	1.000			19,44 €
	ARMAE 120.4	120 Cm 4'lü	1,99	169	145	1.200			23,33 €
	ARMAE 150.4	150 Cm 4'lü	2,53	215	185	1.500			29,17 €
	ARMAE 170.4	170 Cm 4'lü	2,90	246	212	1.700			33,06 €
	ARMAE 200.4	200 Cm 4'lü	3,44	292	251	2.000			38,89 €
	ARMAE 220.4	220 Cm 4'lü	3,80	323	278	2.200			42,78 €
	ARMAE 250.4	250 Cm 4'lü	4,35	369	317	2.500			48,61 €
	ARMAE 270.4	270 Cm 4'lü	4,71	400	344	2.700			52,50 €
ARMAE 300.4	300 Cm 4'lü	5,25	446	383	3.000	58,33 €			

12 mm	ARMAE 75.6	75 Cm 6'lı	1,77	150	129	750	55	336	21,88 €
	ARMAE 100.6	100 Cm 6'lı	2,44	208	178	1.000			29,17 €
	ARMAE 120.6	120 Cm 6'lı	2,99	254	218	1.200			35,00 €
	ARMAE 150.6	150 Cm 6'lı	3,80	323	278	1.500			43,75 €
	ARMAE 170.6	170 Cm 6'lı	4,35	369	317	1.700			49,58 €
	ARMAE 200.6	200 Cm 6'lı	5,16	439	377	2.000			58,33 €
	ARMAE 220.6	220 Cm 6'lı	5,70	485	416	2.200			64,17 €
	ARMAE 250.6	250 Cm 6'lı	6,52	554	476	2.500			72,92 €
	ARMAE 270.6	270 Cm 6'lı	7,06	600	516	2.700			78,75 €
ARMAE 300.6	300 Cm 6'lı	7,88	669	575	3.000	87,50 €			

\* ARMAE 1/2" MARKET ALT SOĞUTUCULAR Metre Fiyatları 4,87 €

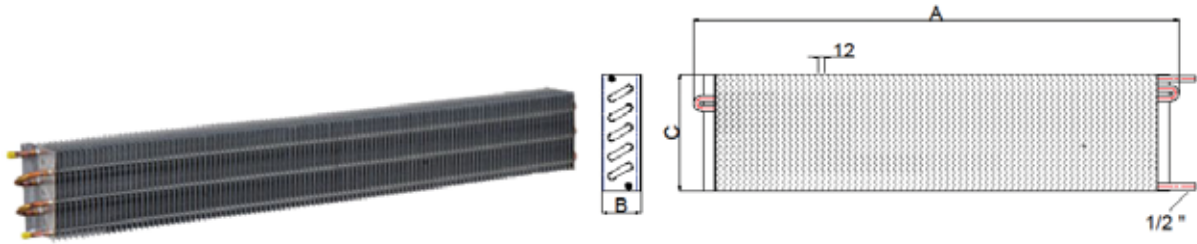

**12 ARMUE SERİSİ MARKET ÜST EVAPORATÖR**  
12 ARMUE SERIES GRAVITY COLLERS FOR SHOP WINDOWS

Lamel Aralığı Fin Spacing	KOD CODE	MODEL MODEL	Isı Transfer Alanı Heat Transfer Area	Kapasite Capacity		Boyutlar Dimension			Fiyat Price
				(R 404 A)		A	B	C	
				m <sup>2</sup>	Watt	kcal/h	mm	mm	
<b>5648-1/2"</b>									
12 mm	1/2"-12 ARMUE 75.3.2	75 Cm 6'lı	1,77	150	129	750	100	170	21,88 €
	1/2"-12 ARMUE 100.3.2	100 Cm 6'lı	2,44	208	178	1.000			29,17 €
	1/2"-12 ARMUE 120.3.2	120 Cm 6'lı	2,99	254	218	1.200			35,00 €
	1/2"-12 ARMUE 150.3.2	150 Cm 6'lı	3,80	323	278	1.500			43,75 €
	1/2"-12 ARMUE 170.3.2	170 Cm 6'lı	4,35	369	317	1.700			49,58 €
	1/2"-12 ARMUE 200.3.2	200 Cm 6'lı	5,16	439	377	2.000			58,33 €
	1/2"-12 ARMUE 220.3.2	220 Cm 6'lı	5,70	485	416	2.200			64,17 €
	1/2"-12 ARMUE 250.3.2	250 Cm 6'lı	6,52	554	476	2.500			72,92 €
	1/2"-12 ARMUE 270.3.2	270 Cm 6'lı	7,06	600	516	2.700			78,75 €
1/2"-12 ARMUE 300.3.2	300 Cm 6'lı	7,88	669	575	3.000	87,50 €			
12 mm	1/2"-12 ARMUE 750.4.2	75 Cm 8'li	2,35	200	172	750	100	224	29,17 €
	1/2"-12 ARMUE 100.4.2	100 Cm 8'li	3,26	277	238	1.000			38,89 €
	1/2"-12 ARMUE 120.4.2	120 Cm 8'li	3,98	339	291	1.200			46,67 €
	1/2"-12 ARMUE 150.4.2	150 Cm 8'li	5,07	431	370	1.500			58,33 €
	1/2"-12 ARMUE 170.4.2	170 Cm 8'li	5,79	493	423	1.700			66,11 €
	1/2"-12 ARMUE 200.4.2	200 Cm 8'li	6,88	585	502	2.000			77,78 €
	1/2"-12 ARMUE 220.4.2	220 Cm 8'li	7,60	646	555	2.200			85,56 €
	1/2"-12 ARMUE 250.4.2	250 Cm 8'li	8,69	739	635	2.500			97,22 €
	1/2"-12 ARMUE 270.4.2	270 Cm 8'li	9,42	800	687	2.700			105,00 €
1/2"-12 ARMUE 300.4.2	300 Cm 8'li	10,50	893	767	3.000	116,67 €			
12 mm	1/2"-12 ARMUE 750.5.2	75 Cm 10'lu	2,94	250	215	750	100	280	36,46 €
	1/2"-12 ARMUE 100.5.2	100 Cm 10'lu	4,07	346	297	1.000			48,61 €
	1/2"-12 ARMUE 120.5.2	120 Cm 10'lu	4,98	423	364	1.200			58,33 €
	1/2"-12 ARMUE 150.5.2	150 Cm 10'lu	6,34	539	463	1.500			72,92 €
	1/2"-12 ARMUE 170.5.2	170 Cm 10'lu	7,24	616	529	1.700			82,64 €
	1/2"-12 ARMUE 200.5.2	200 Cm 10'lu	8,60	731	628	2.000			97,22 €
	1/2"-12 ARMUE 220.5.2	220 Cm 10'lu	9,51	808	694	2.200			106,94 €
	1/2"-12 ARMUE 250.5.2	250 Cm 10'lu	10,86	923	793	2.500			121,53 €
	1/2"-12 ARMUE 270.5.2	270 Cm 10'lu	11,77	1.000	859	2.700			131,25 €
1/2"-12 ARMUE 300.5.2	300 Cm 10'lu	13,13	1.116	958	3.000	145,83 €			
12 mm	1/2"-12 ARMUE 75.6.2	75 Cm 12'li	3,53	300	258	750	100	336	43,75 €
	1/2"-12 ARMUE 100.6.2	100 Cm 12'li	4,89	416	357	1.000			58,33 €
	1/2"-12 ARMUE 120.6.2	120 Cm 12'li	5,98	508	436	1.200			70,00 €
	1/2"-12 ARMUE 150.6.2	150 Cm 12'li	7,60	646	555	1.500			87,50 €
	1/2"-12 ARMUE 170.6.2	170 Cm 12'li	8,69	739	635	1.700			99,17 €
	1/2"-12 ARMUE 200.6.2	200 Cm 12'li	10,32	877	754	2.000			116,67 €
	1/2"-12 ARMUE 220.6.2	220 Cm 12'li	11,41	970	833	2.200			128,33 €
	1/2"-12 ARMUE 250.6.2	250 Cm 12'li	13,04	1.108	952	2.500			145,83 €
	1/2"-12 ARMUE 270.6.2	270 Cm 12'li	14,12	1.200	1031	2.700			157,50 €
1/2"-12 ARMUE 300.6.2	300 Cm 12'li	15,75	1.339	1150	3.000	175,00 €			

\* ARMUE 1/2" -12mm 2 Sıralı MARKET ÜST SOĞUTUCULAR Metre Fiyatları 4,87 €

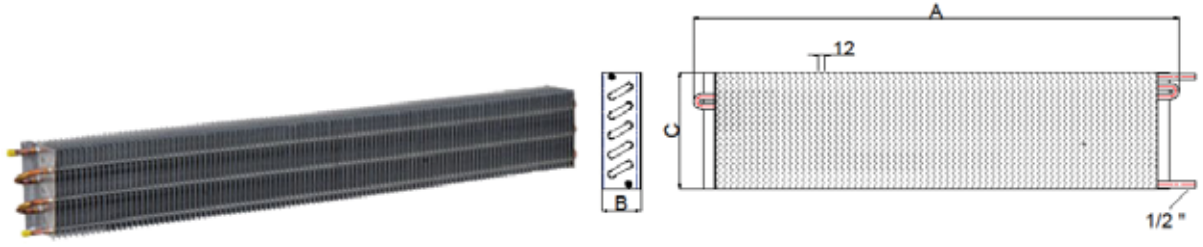

### 10 ARMUE SERİSİ MARKET ÜST EVAPORATÖR 10 ARMUE SERIES GRAVITY COLLERS FOR SHOP WINDOWS

Lamel Aralığı Fin Spacing	KOD CODE	MODEL MODEL	Isı Transfer Alanı Heat Transfer Area	Kapasite Capacity		Boyutlar Dimension			Fiyat Price
				(R 404 A)		A	B	C	
				m <sup>2</sup>	Watt	kcal/h	mm	mm	
<b>5648-1/2"</b>									
10 mm	1/2"-10 ARMUE 75.3.2	75 Cm 6'lı	2,12	180	155	750	100	170	25,00 €
	1/2"-10 ARMUE 100.3.2	100 Cm 6'lı	2,93	249	214	1.000			33,33 €
	1/2"-10 ARMUE 120.3.2	120 Cm 6'lı	3,59	305	262	1.200			40,00 €
	1/2"-10 ARMUE 150.3.2	150 Cm 6'lı	4,56	388	333	1.500			50,00 €
	1/2"-10 ARMUE 170.3.2	170 Cm 6'lı	5,21	443	381	1.700			56,67 €
	1/2"-10 ARMUE 200.3.2	200 Cm 6'lı	6,19	526	452	2.000			66,67 €
	1/2"-10 ARMUE 220.3.2	220 Cm 6'lı	6,84	582	500	2.200			73,33 €
	1/2"-10 ARMUE 250.3.2	250 Cm 6'lı	7,82	665	571	2.500			83,33 €
	1/2"-10 ARMUE 270.3.2	270 Cm 6'lı	8,47	720	619	2.700			90,00 €
1/2"-10 ARMUE 300.3.2	300 Cm 6'lı	9,45	803	690	3.000	100,00 €			
10 mm	1/2"-10 ARMUE 75.4.2	75 Cm 8'li	2,82	240	206	750	100	224	33,33 €
	1/2"-10 ARMUE 100.4.2	100 Cm 8'li	3,91	332	286	1.000			44,44 €
	1/2"-10 ARMUE 120.4.2	120 Cm 8'li	4,78	406	349	1.200			53,33 €
	1/2"-10 ARMUE 150.4.2	150 Cm 8'li	6,08	517	444	1.500			66,67 €
	1/2"-10 ARMUE 170.4.2	170 Cm 8'li	6,95	591	508	1.700			75,56 €
	1/2"-10 ARMUE 200.4.2	200 Cm 8'li	8,26	702	603	2.000			88,89 €
	1/2"-10 ARMUE 220.4.2	220 Cm 8'li	9,13	776	666	2.200			97,78 €
	1/2"-10 ARMUE 250.4.2	250 Cm 8'li	10,43	887	762	2.500			111,11 €
	1/2"-10 ARMUE 270.4.2	270 Cm 8'li	11,30	960	825	2.700			120,00 €
1/2"-10 ARMUE 300.4.2	300 Cm 8'li	12,60	1.071	920	3.000	133,33 €			
10 mm	1/2"-10 ARMUE 750.5.2	75 Cm 10'lu	3,53	300	258	750	100	280	41,67 €
	1/2"-10 ARMUE 100.5.2	100 Cm 10'lu	4,89	416	357	1.000			55,56 €
	1/2"-10 ARMUE 120.5.2	120 Cm 10'lu	5,98	508	436	1.200			66,67 €
	1/2"-10 ARMUE 150.5.2	150 Cm 10'lu	7,60	646	555	1.500			83,33 €
	1/2"-10 ARMUE 170.5.2	170 Cm 10'lu	8,69	739	635	1.700			94,44 €
	1/2"-10 ARMUE 200.5.2	200 Cm 10'lu	10,32	877	754	2.000			111,11 €
	1/2"-10 ARMUE 220.5.2	220 Cm 10'lu	11,41	970	833	2.200			122,22 €
	1/2"-10 ARMUE 250.5.2	250 Cm 10'lu	13,04	1.108	952	2.500			138,89 €
	1/2"-10 ARMUE 270.5.2	270 Cm 10'lu	14,12	1.200	1031	2.700			150,00 €
1/2"-10 ARMUE 300.5.2	300 Cm 10'lu	15,75	1.339	1150	3.000	166,67 €			
10 mm	1/2"-10 ARMUE 75.6.2	75 Cm 12'li	4,24	360	309	750	100	336	50,00 €
	1/2"-10 ARMUE 100.6.2	100 Cm 12'li	5,87	499	428	1.000			66,67 €
	1/2"-10 ARMUE 120.6.2	120 Cm 12'li	7,17	609	524	1.200			80,00 €
	1/2"-10 ARMUE 150.6.2	150 Cm 12'li	9,13	776	666	1.500			100,00 €
	1/2"-10 ARMUE 170.6.2	170 Cm 12'li	10,43	887	762	1.700			113,33 €
	1/2"-10 ARMUE 200.6.2	200 Cm 12'li	12,38	1.053	904	2.000			133,33 €
	1/2"-10 ARMUE 220.6.2	220 Cm 12'li	13,69	1.164	999	2.200			146,67 €
	1/2"-10 ARMUE 250.6.2	250 Cm 12'li	15,64	1.330	1142	2.500			166,67 €
	1/2"-10 ARMUE 270.6.2	270 Cm 12'li	16,95	1.441	1237	2.700			180,00 €
1/2"-10 ARMUE 300.6.2	300 Cm 12'li	18,90	1.607	1380	3.000	200,00 €			

\* ARMUE 1/2" -10mm 2 Sıralı MARKET ÜST SOĞUTUCULAR Metre Fiyatları 5,56 €

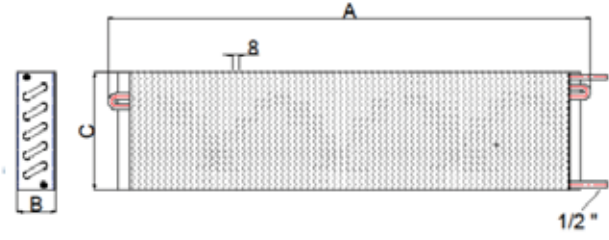
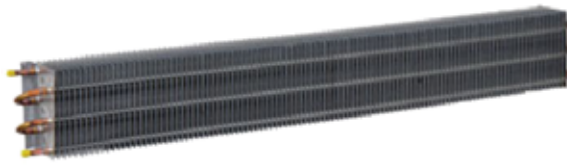

### 8 ARMUE SERİSİ MARKET ÜST EVAPORATÖR 8 ARMUE SERIES GRAVITY COLLERS FOR SHOP WINDOWS

Lamel Aralığı Fin Spacing	KOD CODE	MODEL MODEL	Isı Transfer Alanı Heat Transfer Area	Kapasite Capacity		Boyutlar Dimension			Fiyat Price
				(R 404 A)		A	B	C	
				m <sup>2</sup>	Watt	kcal/h	mm	mm	
<b>5648-1/2"</b>									
8 mm	1/2"-8 ARMUE 750.3.2	75 Cm 6'lı	2,65	225	193	750	100	170	26,88 €
	1/2"-8 ARMUE 1000.3.2	100 Cm 6'lı	3,67	312	268	1.000			35,83 €
	1/2"-8 ARMUE 1200.3.2	120 Cm 6'lı	4,48	381	327	1.200			43,00 €
	1/2"-8 ARMUE 1500.3.2	150 Cm 6'lı	5,70	485	416	1.500			53,75 €
	1/2"-8 ARMUE 1700.3.2	170 Cm 6'lı	6,52	554	476	1.700			60,92 €
	1/2"-8 ARMUE 2000.3.2	200 Cm 6'lı	7,74	658	565	2.000			71,67 €
	1/2"-8 ARMUE 2200.3.2	220 Cm 6'lı	8,56	727	625	2.200			78,83 €
	1/2"-8 ARMUE 2500.3.2	250 Cm 6'lı	9,78	831	714	2.500			89,58 €
	1/2"-8 ARMUE 2700.3.2	270 Cm 6'lı	10,59	900	773	2.700			96,75 €
	1/2"-8 ARMUE 3000.3.2	300 Cm 6'lı	11,81	1.004	863	3.000			107,50 €
8 mm	1/2"-8 ARMUE 750.4.2	75 Cm 8'li	3,53	300	258	750	100	224	35,83 €
	1/2"-8 ARMUE 1000.4.2	100 Cm 8'li	4,89	416	357	1.000			47,78 €
	1/2"-8 ARMUE 1200.4.2	120 Cm 8'li	5,98	508	436	1.200			57,33 €
	1/2"-8 ARMUE 1500.4.2	150 Cm 8'li	7,60	646	555	1.500			71,67 €
	1/2"-8 ARMUE 1700.4.2	170 Cm 8'li	8,69	739	635	1.700			81,22 €
	1/2"-8 ARMUE 2000.4.2	200 Cm 8'li	10,32	877	754	2.000			95,56 €
	1/2"-8 ARMUE 2200.4.2	220 Cm 8'li	11,41	970	833	2.200			105,11 €
	1/2"-8 ARMUE 2500.4.2	250 Cm 8'li	13,04	1.108	952	2.500			119,44 €
	1/2"-8 ARMUE 2700.4.2	270 Cm 8'li	14,12	1.200	1031	2.700			129,00 €
	1/2"-8 ARMUE 3000.4.2	300 Cm 8'li	15,75	1.339	1150	3.000			143,33 €
8 mm	1/2"-8 ARMUE 750.5.2	75 Cm 10'lu	4,41	375	322	750	100	280	44,79 €
	1/2"-8 ARMUE 1000.5.2	100 Cm 10'lu	6,11	519	446	1.000			59,72 €
	1/2"-8 ARMUE 1200.5.2	120 Cm 10'lu	7,47	635	545	1.200			71,67 €
	1/2"-8 ARMUE 1500.5.2	150 Cm 10'lu	9,51	808	694	1.500			89,58 €
	1/2"-8 ARMUE 1700.5.2	170 Cm 10'lu	10,86	923	793	1.700			101,53 €
	1/2"-8 ARMUE 2000.5.2	200 Cm 10'lu	12,90	1.097	942	2.000			119,44 €
	1/2"-8 ARMUE 2200.5.2	220 Cm 10'lu	14,26	1.212	1041	2.200			131,39 €
	1/2"-8 ARMUE 2500.5.2	250 Cm 10'lu	16,30	1.385	1190	2.500			149,31 €
	1/2"-8 ARMUE 2700.5.2	270 Cm 10'lu	17,65	1.501	1289	2.700			161,25 €
	1/2"-8 ARMUE 3000.5.2	300 Cm 10'lu	19,69	1.674	1438	3.000			179,17 €
8 mm	1/2"-8 ARMUE 750.6.2	75 Cm 12'li	5,30	450	387	750	100	336	53,75 €
	1/2"-8 ARMUE 1000.6.2	100 Cm 12'li	7,33	623	535	1.000			71,67 €
	1/2"-8 ARMUE 1200.6.2	120 Cm 12'li	8,96	762	654	1.200			86,00 €
	1/2"-8 ARMUE 1500.6.2	150 Cm 12'li	11,41	970	833	1.500			107,50 €
	1/2"-8 ARMUE 1700.6.2	170 Cm 12'li	13,04	1.108	952	1.700			121,83 €
	1/2"-8 ARMUE 2000.6.2	200 Cm 12'li	15,48	1.316	1130	2.000			143,33 €
	1/2"-8 ARMUE 2200.6.2	220 Cm 12'li	17,11	1.454	1249	2.200			157,67 €
	1/2"-8 ARMUE 2500.6.2	250 Cm 12'li	19,56	1.662	1428	2.500			179,17 €
	1/2"-8 ARMUE 2700.6.2	270 Cm 12'li	21,18	1.801	1547	2.700			193,50 €
	1/2"-8 ARMUE 3000.6.2	300 Cm 12'li	23,63	2.008	1725	3.000			215,00 €

\* ARMUE 1/2" -8mm 2 Sıralı MARKET ÜST SOĞUTUCULAR Metre Fiyatları 5,97 €

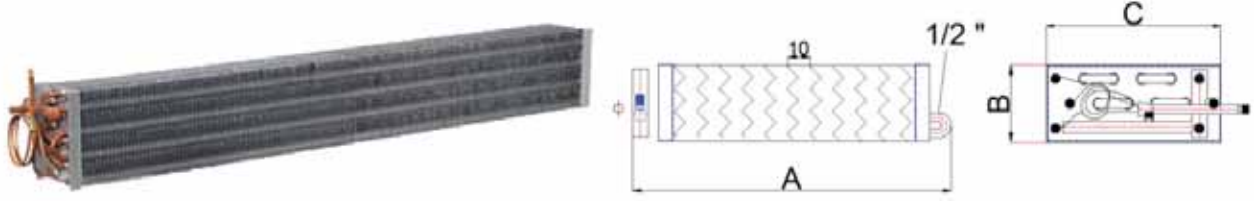

**10 ARMUE SERİSİ MARKET ÜST EVAPORATÖR**  
**10 ARMUE SERIES GRAVITY COLLERS FOR SHOP WINDOWS**

Lamel Aralığı Fin Spacing	KOD CODE	MODEL MODEL	Isı Transfer Alanı Heat Transfer Area	Kapasite Capacity		Boyutlar Dimension			Fiyat Price
				(R 404 A)		A	B	C	
				m <sup>2</sup>	Watt	kcal/h	mm	mm	
<b>5648-1/2"</b>									
10 mm	1/2"-10 ARMUE 750.3.3	75 Cm 9'lu	3,18	270	232	750	150	170	37,50 €
	1/2"-10 ARMUE 1000.3.3	100 Cm 9'lu	4,40	374	321	1.000			50,00 €
	1/2"-10 ARMUE 1200.3.3	120 Cm 9'lu	5,38	457	393	1.200			60,00 €
	1/2"-10 ARMUE 1500.3.3	150 Cm 9'lu	6,84	582	500	1.500			75,00 €
	1/2"-10 ARMUE 1700.3.3	170 Cm 9'lu	7,82	665	571	1.700			85,00 €
	1/2"-10 ARMUE 2000.3.3	200 Cm 9'lu	9,29	790	678	2.000			100,00 €
	1/2"-10 ARMUE 2200.3.3	220 Cm 9'lu	10,27	873	750	2.200			110,00 €
	1/2"-10 ARMUE 2500.3.3	250 Cm 9'lu	11,73	997	857	2.500			125,00 €
	1/2"-10 ARMUE 2700.3.3	270 Cm 9'lu	12,71	1.080	928	2.700			135,00 €
	1/2"-10 ARMUE 3000.3.3	300 Cm 9'lu	14,18	1.205	1035	3.000			150,00 €
10 mm	1/2"-10 ARMUE 750.4.3	75 Cm 12'li	4,24	360	309	750	150	224	50,00 €
	1/2"-10 ARMUE 1000.4.3	100 Cm 12'li	5,87	499	428	1.000			66,67 €
	1/2"-10 ARMUE 1200.4.3	120 Cm 12'li	7,17	609	524	1.200			80,00 €
	1/2"-10 ARMUE 1500.4.3	150 Cm 12'li	9,13	776	666	1.500			100,00 €
	1/2"-10 ARMUE 1700.4.3	170 Cm 12'li	10,43	887	762	1.700			113,33 €
	1/2"-10 ARMUE 2000.4.3	200 Cm 12'li	12,38	1.053	904	2.000			133,33 €
	1/2"-10 ARMUE 2200.4.3	220 Cm 12'li	13,69	1.164	999	2.200			146,67 €
	1/2"-10 ARMUE 2500.4.3	250 Cm 12'li	15,64	1.330	1142	2.500			166,67 €
	1/2"-10 ARMUE 2700.4.3	270 Cm 12'li	16,95	1.441	1237	2.700			180,00 €
	1/2"-10 ARMUE 3000.4.3	300 Cm 12'li	18,90	1.607	1380	3.000			200,00 €
10 mm	1/2"-10 ARMUE 7500.5.3	75 Cm 15'li	5,30	450	387	750	150	280	62,50 €
	1/2"-10 ARMUE 1000.5.3	100 Cm 15'li	7,33	623	535	1.000			83,33 €
	1/2"-10 ARMUE 1200.5.3	120 Cm 15'li	8,96	762	654	1.200			100,00 €
	1/2"-10 ARMUE 1500.5.3	150 Cm 15'li	11,41	970	833	1.500			125,00 €
	1/2"-10 ARMUE 1700.5.3	170 Cm 15'li	13,04	1.108	952	1.700			141,67 €
	1/2"-10 ARMUE 2000.5.3	200 Cm 15'li	15,48	1.316	1130	2.000			166,67 €
	1/2"-10 ARMUE 2200.5.3	220 Cm 15'li	17,11	1.454	1249	2.200			183,33 €
	1/2"-10 ARMUE 2500.5.3	250 Cm 15'li	19,56	1.662	1428	2.500			208,33 €
	1/2"-10 ARMUE 2700.5.3	270 Cm 15'li	21,18	1.801	1547	2.700			225,00 €
	1/2"-10 ARMUE 3000.5.3	300 Cm 15'li	23,63	2.008	1725	3.000			250,00 €
10 mm	1/2"-10 ARMUE 750.6.3	75 Cm 18'li	6,36	540	464	750	150	336	75,00 €
	1/2"-10 ARMUE 1000.6.3	100 Cm 18'li	8,80	748	643	1.000			100,00 €
	1/2"-10 ARMUE 1200.6.3	120 Cm 18'li	10,76	914	785	1.200			120,00 €
	1/2"-10 ARMUE 1500.6.3	150 Cm 18'li	13,69	1.164	999	1.500			150,00 €
	1/2"-10 ARMUE 1700.6.3	170 Cm 18'li	15,64	1.330	1142	1.700			170,00 €
	1/2"-10 ARMUE 2000.6.3	200 Cm 18'li	18,58	1.579	1356	2.000			200,00 €
	1/2"-10 ARMUE 2200.6.3	220 Cm 18'li	20,53	1.745	1499	2.200			220,00 €
	1/2"-10 ARMUE 2500.6.3	250 Cm 18'li	23,47	1.995	1713	2.500			250,00 €
	1/2"-10 ARMUE 2700.6.3	270 Cm 18'li	25,42	2.161	1856	2.700			270,00 €
	1/2"-10 ARMUE 3000.6.3	300 Cm 18'li	28,36	2.410	2070	3.000			300,00 €

\* ARMUE 1/2" -10mm 3 Sıralı MARKET ÜST SOĞUTUCULAR Metre Fiyatları 5,56 €



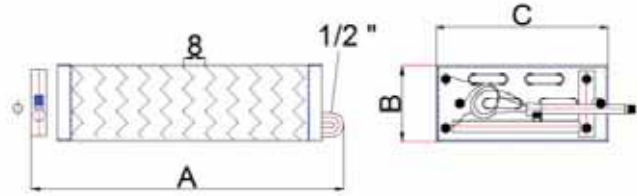

### 8 ARMUE SERİSİ MARKET ÜST EVAPORATÖR 8 ARMUE SERIES GRAVITY COLLERS FOR SHOP WINDOWS

Lamel Aralığı Fin Spacing	KOD CODE	MODEL MODEL	Isı Transfer Alanı Heat Transfer Area	Kapasite Capacity (R 404 A)		Boyutlar Dimension			Fiyat Price €	
				m <sup>2</sup>	Watt	kcal/h	A	B		C
							mm	mm		mm
<b>5648-1/2"</b>										
8 mm	1/2"-8 ARMUE 750.3.3	75 Cm 9'lu	3,97	338	290	750	150	170	40,31 €	
	1/2"-8 ARMUE 1000.3.3	100 Cm 9'lu	5,50	467	402	1.000			53,75 €	
	1/2"-8 ARMUE 1200.3.3	120 Cm 9'lu	6,72	571	491	1.200			64,50 €	
	1/2"-8 ARMUE 1500.3.3	150 Cm 9'lu	8,56	727	625	1.500			80,63 €	
	1/2"-8 ARMUE 1700.3.3	170 Cm 9'lu	9,78	831	714	1.700			91,38 €	
	1/2"-8 ARMUE 2000.3.3	200 Cm 9'lu	11,61	987	848	2.000			107,50 €	
	1/2"-8 ARMUE 2200.3.3	220 Cm 9'lu	12,83	1.091	937	2.200			118,25 €	
	1/2"-8 ARMUE 2500.3.3	250 Cm 9'lu	14,67	1.247	1071	2.500			134,38 €	
	1/2"-8 ARMUE 2700.3.3	270 Cm 9'lu	15,89	1.351	1160	2.700			145,13 €	
	1/2"-8 ARMUE 3000.3.3	300 Cm 9'lu	17,72	1.506	1294	3.000			161,25 €	
8 mm	1/2"-8 ARMUE 750.4.3	75 Cm 12'li	5,30	450	387	750	150	224	53,75 €	
	1/2"-8 ARMUE 1000.4.3	100 Cm 12'li	7,33	623	535	1.000			71,67 €	
	1/2"-8 ARMUE 1200.4.3	120 Cm 12'li	8,96	762	654	1.200			86,00 €	
	1/2"-8 ARMUE 1500.4.3	150 Cm 12'li	11,41	970	833	1.500			107,50 €	
	1/2"-8 ARMUE 1700.4.3	170 Cm 12'li	13,04	1.108	952	1.700			121,83 €	
	1/2"-8 ARMUE 2000.4.3	200 Cm 12'li	15,48	1.316	1130	2.000			143,33 €	
	1/2"-8 ARMUE 2200.4.3	220 Cm 12'li	17,11	1.454	1249	2.200			157,67 €	
	1/2"-8 ARMUE 2500.4.3	250 Cm 12'li	19,56	1.662	1428	2.500			179,17 €	
	1/2"-8 ARMUE 2700.4.3	270 Cm 12'li	21,18	1.801	1547	2.700			193,50 €	
	1/2"-8 ARMUE 3000.4.3	300 Cm 12'li	23,63	2.008	1725	3.000			215,00 €	
8 mm	1/2"-8 ARMUE 7500.5.3	75 Cm 15'li	6,62	563	483	750	150	280	67,19 €	
	1/2"-8 ARMUE 1000.5.3	100 Cm 15'li	9,17	779	669	1.000			89,58 €	
	1/2"-8 ARMUE 1200.5.3	120 Cm 15'li	11,20	952	818	1.200			107,50 €	
	1/2"-8 ARMUE 1500.5.3	150 Cm 15'li	14,26	1.212	1041	1.500			134,38 €	
	1/2"-8 ARMUE 1700.5.3	170 Cm 15'li	16,30	1.385	1190	1.700			152,29 €	
	1/2"-8 ARMUE 2000.5.3	200 Cm 15'li	19,35	1.645	1413	2.000			179,17 €	
	1/2"-8 ARMUE 2200.5.3	220 Cm 15'li	21,39	1.818	1562	2.200			197,08 €	
	1/2"-8 ARMUE 2500.5.3	250 Cm 15'li	24,44	2.078	1785	2.500			223,96 €	
	1/2"-8 ARMUE 2700.5.3	270 Cm 15'li	26,48	2.251	1934	2.700			241,88 €	
	1/2"-8 ARMUE 3000.5.3	300 Cm 15'li	29,54	2.511	2157	3.000			268,75 €	
8 mm	1/2"-8 ARMUE 750.6.3	75 Cm 18'li	7,94	675	580	750	150	336	80,63 €	
	1/2"-8 ARMUE 1000.6.3	100 Cm 18'li	11,00	935	803	1.000			107,50 €	
	1/2"-8 ARMUE 1200.6.3	120 Cm 18'li	13,44	1.143	982	1.200			129,00 €	
	1/2"-8 ARMUE 1500.6.3	150 Cm 18'li	17,11	1.454	1249	1.500			161,25 €	
	1/2"-8 ARMUE 1700.6.3	170 Cm 18'li	19,56	1.662	1428	1.700			182,75 €	
	1/2"-8 ARMUE 2000.6.3	200 Cm 18'li	23,22	1.974	1696	2.000			215,00 €	
	1/2"-8 ARMUE 2200.6.3	220 Cm 18'li	25,67	2.182	1874	2.200			236,50 €	
	1/2"-8 ARMUE 2500.6.3	250 Cm 18'li	29,33	2.493	2142	2.500			268,75 €	
	1/2"-8 ARMUE 2700.6.3	270 Cm 18'li	31,78	2.701	2320	2.700			290,25 €	
	1/2"-8 ARMUE 3000.6.3	300 Cm 18'li	35,44	3.013	2588	3.000			322,50 €	

\* ARMUE 1/2" -8mm 3 Sıralı MARKET ÜST SOĞUTUCULAR Metre Fiyatları 5,97 €

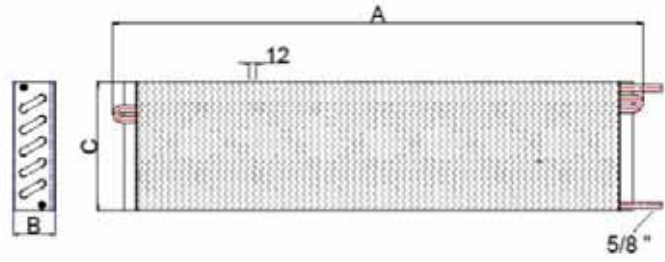

### 12 ARMUE SERİSİ MARKET ÜST EVAPORATÖR 12 ARMUE SERIES GRAVITY COLLERS FOR SHOP WINDOWS

Lamel Aralığı Fin Spacing	KOD CODE	MODEL MODEL	Isı Transfer Alanı Heat Transfer Area	Kapasite Capacity		Boyutlar Dimension			Fiyat Price
				(R 404 A)		A	B	C	
				m <sup>2</sup>	Watt	kcal/h	mm	mm	

5648-5/8"									
12 mm	5/8"-12 ARMUE 750.3.2	75 Cm 6'lı	1,77	150	129	750	100	170	25,00 €
	5/8"-12 ARMUE 1000.3.2	100 Cm 6'lı	2,44	208	178	1.000			33,33 €
	5/8"-12 ARMUE 1200.3.2	120 Cm 6'lı	2,99	254	218	1.200			40,00 €
	5/8"-12 ARMUE 1500.3.2	150 Cm 6'lı	3,80	323	278	1.500			50,00 €
	5/8"-12 ARMUE 1700.3.2	170 Cm 6'lı	4,35	369	317	1.700			56,67 €
	5/8"-12 ARMUE 2000.3.2	200 Cm 6'lı	5,16	439	377	2.000			66,67 €
	5/8"-12 ARMUE 2200.3.2	220 Cm 6'lı	5,70	485	416	2.200			73,33 €
	5/8"-12 ARMUE 2500.3.2	250 Cm 6'lı	6,52	554	476	2.500			83,33 €
	5/8"-12 ARMUE 2700.3.2	270 Cm 6'lı	7,06	600	516	2.700			90,00 €
5/8"-12 ARMUE 3000.3.2	300 Cm 6'lı	7,88	669	575	3.000	100,00 €			

12 mm	5/8"-12 ARMUE 7500.4.2	75 Cm 8'li	2,35	200	172	750	100	224	33,33 €
	5/8"-12 ARMUE 1000.4.2	100 Cm 8'li	3,26	277	238	1.000			44,44 €
	5/8"-12 ARMUE 1200.4.2	120 Cm 8'li	3,98	339	291	1.200			53,33 €
	5/8"-12 ARMUE 1500.4.2	150 Cm 8'li	5,07	431	370	1.500			66,67 €
	5/8"-12 ARMUE 1700.4.2	170 Cm 8'li	5,79	493	423	1.700			75,56 €
	5/8"-12 ARMUE 2000.4.2	200 Cm 8'li	6,88	585	502	2.000			88,89 €
	5/8"-12 ARMUE 2200.4.2	220 Cm 8'li	7,60	646	555	2.200			97,78 €
	5/8"-12 ARMUE 2500.4.2	250 Cm 8'li	8,69	739	635	2.500			111,11 €
	5/8"-12 ARMUE 2700.4.2	270 Cm 8'li	9,42	800	687	2.700			120,00 €
5/8"-12 ARMUE 3000.4.2	300 Cm 8'li	10,50	893	767	3.000	133,33 €			

12 mm	5/8"-12 ARMUE 7500.5.2	75 Cm 10'lu	2,94	250	215	750	100	280	41,67 €
	5/8"-12 ARMUE 1000.5.2	100 Cm 10'lu	4,07	346	297	1.000			55,56 €
	5/8"-12 ARMUE 1200.5.2	120 Cm 10'lu	4,98	423	364	1.200			66,67 €
	5/8"-12 ARMUE 1500.5.2	150 Cm 10'lu	6,34	539	463	1.500			83,33 €
	5/8"-12 ARMUE 1700.5.2	170 Cm 10'lu	7,24	616	529	1.700			94,44 €
	5/8"-12 ARMUE 2000.5.2	200 Cm 10'lu	8,60	731	628	2.000			111,11 €
	5/8"-12 ARMUE 2200.5.2	220 Cm 10'lu	9,51	808	694	2.200			122,22 €
	5/8"-12 ARMUE 2500.5.2	250 Cm 10'lu	10,86	923	793	2.500			138,89 €
	5/8"-12 ARMUE 2700.5.2	270 Cm 10'lu	11,77	1.000	859	2.700			150,00 €
5/8"-12 ARMUE 3000.5.2	300 Cm 10'lu	13,13	1.116	958	3.000	166,67 €			

12 mm	5/8"-12 ARMUE 750.6.2	75 Cm 12'li	3,53	300	258	750	100	336	50,00 €
	5/8"-12 ARMUE 1000.6.2	100 Cm 12'li	4,89	416	357	1.000			66,67 €
	5/8"-12 ARMUE 1200.6.2	120 Cm 12'li	5,98	508	436	1.200			80,00 €
	5/8"-12 ARMUE 1500.6.2	150 Cm 12'li	7,60	646	555	1.500			100,00 €
	5/8"-12 ARMUE 1700.6.2	170 Cm 12'li	8,69	739	635	1.700			113,33 €
	5/8"-12 ARMUE 2000.6.2	200 Cm 12'li	10,32	877	754	2.000			133,33 €
	5/8"-12 ARMUE 2200.6.2	220 Cm 12'li	11,41	970	833	2.200			146,67 €
	5/8"-12 ARMUE 2500.6.2	250 Cm 12'li	13,04	1.108	952	2.500			166,67 €
	5/8"-12 ARMUE 2700.6.2	270 Cm 12'li	14,12	1.200	1031	2.700			180,00 €
5/8"-12 ARMUE 3000.6.2	300 Cm 12'li	15,75	1.339	1150	3.000	200,00 €			

\* ARMUE 5/8" -12mm 2 Sıralı MARKET ÜST SOĞUTUCULAR Metre Fiyatları 5,56 €

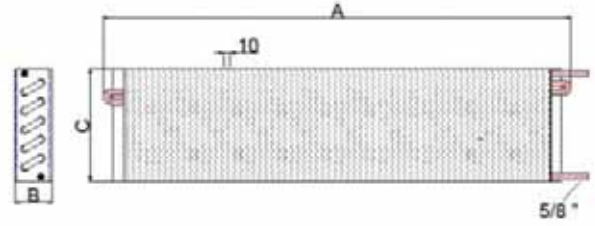

**10 ARMUE SERİSİ MARKET ÜST EVAPORATÖR**  
**10 ARMUE SERIES GRAVITY COLLERS FOR SHOP WINDOWS**

Lamel Aralığı Fin Spacing	KOD CODE	MODEL MODEL	Isı Transfer Alanı Heat Transfer Area	Kapasite Capacity		Boyutlar Dimension			Fiyat Price
				(R 404 A)		A	B	C	
				m <sup>2</sup>	Watt	kcal/h	mm	mm	
<b>5648-5/8"</b>									
10 mm	5/8"-10 ARMUE 750.3.2	75 Cm 6'lı	2,12	180	155	750	100	170	30,00 €
	5/8"-10 ARMUE 1000.3.2	100 Cm 6'lı	2,93	249	214	1.000			40,00 €
	5/8"-10 ARMUE 1200.3.2	120 Cm 6'lı	3,59	305	262	1.200			48,00 €
	5/8"-10 ARMUE 1500.3.2	150 Cm 6'lı	4,56	388	333	1.500			60,00 €
	5/8"-10 ARMUE 1700.3.2	170 Cm 6'lı	5,21	443	381	1.700			68,00 €
	5/8"-10 ARMUE 2000.3.2	200 Cm 6'lı	6,19	526	452	2.000			80,00 €
	5/8"-10 ARMUE 2200.3.2	220 Cm 6'lı	6,84	582	500	2.200			88,00 €
	5/8"-10 ARMUE 2500.3.2	250 Cm 6'lı	7,82	665	571	2.500			100,00 €
	5/8"-10 ARMUE 2700.3.2	270 Cm 6'lı	8,47	720	619	2.700			108,00 €
	5/8"-10 ARMUE 3000.3.2	300 Cm 6'lı	9,45	803	690	3.000			120,00 €
10 mm	5/8"-10 ARMUE 750.4.2	75 Cm 8'li	2,82	240	206	750	100	224	40,00 €
	5/8"-10 ARMUE 1000.4.2	100 Cm 8'li	3,91	332	286	1.000			53,33 €
	5/8"-10 ARMUE 1200.4.2	120 Cm 8'li	4,78	406	349	1.200			64,00 €
	5/8"-10 ARMUE 1500.4.2	150 Cm 8'li	6,08	517	444	1.500			80,00 €
	5/8"-10 ARMUE 1700.4.2	170 Cm 8'li	6,95	591	508	1.700			90,67 €
	5/8"-10 ARMUE 2000.4.2	200 Cm 8'li	8,26	702	603	2.000			106,67 €
	5/8"-10 ARMUE 2200.4.2	220 Cm 8'li	9,13	776	666	2.200			117,33 €
	5/8"-10 ARMUE 2500.4.2	250 Cm 8'li	10,43	887	762	2.500			133,33 €
	5/8"-10 ARMUE 2700.4.2	270 Cm 8'li	11,30	960	825	2.700			144,00 €
	5/8"-10 ARMUE 3000.4.2	300 Cm 8'li	12,60	1.071	920	3.000			160,00 €
10 mm	5/8"-10 ARMUE 7500.5.2	75 Cm 10'lu	3,53	300	258	750	100	280	50,00 €
	5/8"-10 ARMUE 1000.5.2	100 Cm 10'lu	4,89	416	357	1.000			66,67 €
	5/8"-10 ARMUE 1200.5.2	120 Cm 10'lu	5,98	508	436	1.200			80,00 €
	5/8"-10 ARMUE 1500.5.2	150 Cm 10'lu	7,60	646	555	1.500			100,00 €
	5/8"-10 ARMUE 1700.5.2	170 Cm 10'lu	8,69	739	635	1.700			113,33 €
	5/8"-10 ARMUE 2000.5.2	200 Cm 10'lu	10,32	877	754	2.000			133,33 €
	5/8"-10 ARMUE 2200.5.2	220 Cm 10'lu	11,41	970	833	2.200			146,67 €
	5/8"-10 ARMUE 2500.5.2	250 Cm 10'lu	13,04	1.108	952	2.500			166,67 €
	5/8"-10 ARMUE 2700.5.2	270 Cm 10'lu	14,12	1.200	1031	2.700			180,00 €
	5/8"-10 ARMUE 3000.5.2	300 Cm 10'lu	15,75	1.339	1150	3.000			200,00 €
10 mm	5/8"-10 ARMUE 750.6.2	75 Cm 12'li	4,24	360	309	750	100	336	60,00 €
	5/8"-10 ARMUE 1000.6.2	100 Cm 12'li	5,87	499	428	1.000			80,00 €
	5/8"-10 ARMUE 1200.6.2	120 Cm 12'li	7,17	609	524	1.200			96,00 €
	5/8"-10 ARMUE 1500.6.2	150 Cm 12'li	9,13	776	666	1.500			120,00 €
	5/8"-10 ARMUE 1700.6.2	170 Cm 12'li	10,43	887	762	1.700			136,00 €
	5/8"-10 ARMUE 2000.6.2	200 Cm 12'li	12,38	1.053	904	2.000			160,00 €
	5/8"-10 ARMUE 2200.6.2	220 Cm 12'li	13,69	1.164	999	2.200			176,00 €
	5/8"-10 ARMUE 2500.6.2	250 Cm 12'li	15,64	1.330	1142	2.500			200,00 €
	5/8"-10 ARMUE 2700.6.2	270 Cm 12'li	16,95	1.441	1237	2.700			216,00 €
	5/8"-10 ARMUE 3000.6.2	300 Cm 12'li	18,90	1.607	1380	3.000			240,00 €

\* ARMUE 5/8" -10mm 2 Sıralı MARKET ÜST SOĞUTUCULAR Metre Fiyatları 6,66 €

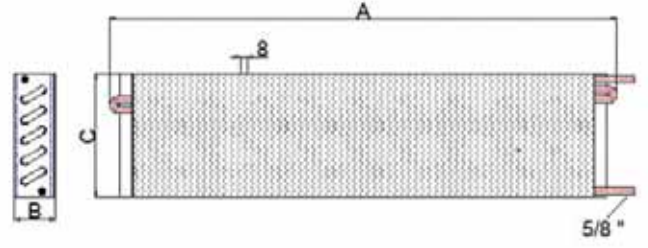

### 8 ARMUE SERİSİ MARKET ÜST EVAPORATÖR 8 ARMUE SERIES GRAVITY COLLERS FOR SHOP WINDOWS

Lamel Aralığı Fin Spacing	KOD CODE	MODEL MODEL	Isı Transfer Alanı Heat Transfer Area	Kapasite Capacity (R 404 A)			Boyutlar Dimension			Fiyat Price €
				m <sup>2</sup>	Watt	kcal/h	A	B	C	
							mm	mm	mm	
<b>5648-1/2"</b>										
8 mm	5/8"-8 ARMUE 750.3.2	75 Cm 6'lı	2,65	225	193	750	100	170	30,63 €	
	5/8"-8 ARMUE 1000.3.2	100 Cm 6'lı	3,67	312	268	1.000			40,83 €	
	5/8"-8 ARMUE 1200.3.2	120 Cm 6'lı	4,48	381	327	1.200			49,00 €	
	5/8"-8 ARMUE 1500.3.2	150 Cm 6'lı	5,70	485	416	1.500			61,25 €	
	5/8"-8 ARMUE 1700.3.2	170 Cm 6'lı	6,52	554	476	1.700			69,42 €	
	5/8"-8 ARMUE 2000.3.2	200 Cm 6'lı	7,74	658	565	2.000			81,67 €	
	5/8"-8 ARMUE 2200.3.2	220 Cm 6'lı	8,56	727	625	2.200			89,83 €	
	5/8"-8 ARMUE 2500.3.2	250 Cm 6'lı	9,78	831	714	2.500			102,08 €	
	5/8"-8 ARMUE 2700.3.2	270 Cm 6'lı	10,59	900	773	2.700			110,25 €	
	5/8"-8 ARMUE 3000.3.2	300 Cm 6'lı	11,81	1.004	863	3.000			122,50 €	
8 mm	5/8"-8 ARMUE 750.4.2	75 Cm 8'li	3,53	300	258	750	100	224	40,83 €	
	5/8"-8 ARMUE 1000.4.2	100 Cm 8'li	4,89	416	357	1.000			54,44 €	
	5/8"-8 ARMUE 1200.4.2	120 Cm 8'li	5,98	508	436	1.200			65,33 €	
	5/8"-8 ARMUE 1500.4.2	150 Cm 8'li	7,60	646	555	1.500			81,67 €	
	5/8"-8 ARMUE 1700.4.2	170 Cm 8'li	8,69	739	635	1.700			92,56 €	
	5/8"-8 ARMUE 2000.4.2	200 Cm 8'li	10,32	877	754	2.000			108,89 €	
	5/8"-8 ARMUE 2200.4.2	220 Cm 8'li	11,41	970	833	2.200			119,78 €	
	5/8"-8 ARMUE 2500.4.2	250 Cm 8'li	13,04	1.108	952	2.500			136,11 €	
	5/8"-8 ARMUE 2700.4.2	270 Cm 8'li	14,12	1.200	1031	2.700			147,00 €	
	5/8"-8 ARMUE 3000.4.2	300 Cm 8'li	15,75	1.339	1150	3.000			163,33 €	
8 mm	5/8"-8 ARMUE 750.5.2	75 Cm 10'lu	4,41	375	322	750	100	280	51,04 €	
	5/8"-8 ARMUE 1000.5.2	100 Cm 10'lu	6,11	519	446	1.000			68,06 €	
	5/8"-8 ARMUE 1200.5.2	120 Cm 10'lu	7,47	635	545	1.200			81,67 €	
	5/8"-8 ARMUE 1500.5.2	150 Cm 10'lu	9,51	808	694	1.500			102,08 €	
	5/8"-8 ARMUE 1700.5.2	170 Cm 10'lu	10,86	923	793	1.700			115,69 €	
	5/8"-8 ARMUE 2000.5.2	200 Cm 10'lu	12,90	1.097	942	2.000			136,11 €	
	5/8"-8 ARMUE 2200.5.2	220 Cm 10'lu	14,26	1.212	1041	2.200			149,72 €	
	5/8"-8 ARMUE 2500.5.2	250 Cm 10'lu	16,30	1.385	1190	2.500			170,14 €	
	5/8"-8 ARMUE 2700.5.2	270 Cm 10'lu	17,65	1.501	1289	2.700			183,75 €	
	5/8"-8 ARMUE 3000.5.2	300 Cm 10'lu	19,69	1.674	1438	3.000			204,17 €	
8 mm	5/8"-8 ARMUE 750.6.2	75 Cm 12'li	5,30	450	387	750	100	336	61,25 €	
	5/8"-8 ARMUE 1000.6.2	100 Cm 12'li	7,33	623	535	1.000			81,67 €	
	5/8"-8 ARMUE 1200.6.2	120 Cm 12'li	8,96	762	654	1.200			98,00 €	
	5/8"-8 ARMUE 1500.6.2	150 Cm 12'li	11,41	970	833	1.500			122,50 €	
	5/8"-8 ARMUE 1700.6.2	170 Cm 12'li	13,04	1.108	952	1.700			138,83 €	
	5/8"-8 ARMUE 2000.6.2	200 Cm 12'li	15,48	1.316	1130	2.000			163,33 €	
	5/8"-8 ARMUE 2200.6.2	220 Cm 12'li	17,11	1.454	1249	2.200			179,67 €	
	5/8"-8 ARMUE 2500.6.2	250 Cm 12'li	19,56	1.662	1428	2.500			204,17 €	
	5/8"-8 ARMUE 2700.6.2	270 Cm 12'li	21,18	1.801	1547	2.700			220,50 €	
	5/8"-8 ARMUE 3000.6.2	300 Cm 12'li	23,63	2.008	1725	3.000			245,00 €	

\* ARMUE 5/8" -10mm 2 Sıralı MARKET ÜST SOĞUTUCULAR Metre Fiyatları 6,8 €

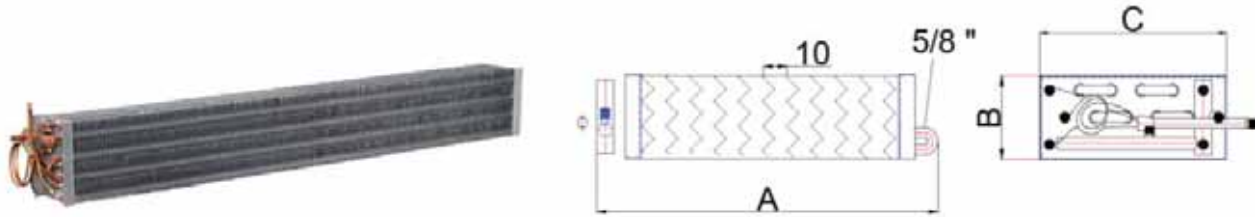

**10 ARMUE SERİSİ MARKET ÜST EVAPORATÖR**  
**10 ARMUE SERIES GRAVITY COLLERS FOR SHOP WINDOWS**

Lamel Aralığı Fin Spacing	KOD CODE	MODEL MODEL	Isı Transfer Alanı Heat Transfer Area	Kapasite Capacity		Boyutlar Dimension			Fiyat Price
				(R 404 A)		A	B	C	
				m <sup>2</sup>	Watt	kcal/h	mm	mm	
<b>5648-1/2"</b>									
10 mm	5/8"-10 ARMUE 750.3.3	75 Cm 9'lu	3,18	270	232	750	150	170	45,00 €
	5/8"-10 ARMUE 1000.3.3	100 Cm 9'lu	4,40	374	321	1.000			60,00 €
	5/8"-10 ARMUE 1200.3.3	120 Cm 9'lu	5,38	457	393	1.200			72,00 €
	5/8"-10 ARMUE 1500.3.3	150 Cm 9'lu	6,84	582	500	1.500			90,00 €
	5/8"-10 ARMUE 1700.3.3	170 Cm 9'lu	7,82	665	571	1.700			102,00 €
	5/8"-10 ARMUE 2000.3.3	200 Cm 9'lu	9,29	790	678	2.000			120,00 €
	5/8"-10 ARMUE 2200.3.3	220 Cm 9'lu	10,27	873	750	2.200			132,00 €
	5/8"-10 ARMUE 2500.3.3	250 Cm 9'lu	11,73	997	857	2.500			150,00 €
	5/8"-10 ARMUE 2700.3.3	270 Cm 9'lu	12,71	1.080	928	2.700			162,00 €
	5/8"-10 ARMUE 3000.3.3	300 Cm 9'lu	14,18	1.205	1035	3.000			180,00 €
10 mm	5/8"-10 ARMUE 750.4.3	75 Cm 12'li	4,24	360	309	750	150	224	60,00 €
	5/8"-10 ARMUE 1000.4.3	100 Cm 12'li	5,87	499	428	1.000			80,00 €
	5/8"-10 ARMUE 1200.4.3	120 Cm 12'li	7,17	609	524	1.200			96,00 €
	5/8"-10 ARMUE 1500.4.3	150 Cm 12'li	9,13	776	666	1.500			120,00 €
	5/8"-10 ARMUE 1700.4.3	170 Cm 12'li	10,43	887	762	1.700			136,00 €
	5/8"-10 ARMUE 2000.4.3	200 Cm 12'li	12,38	1.053	904	2.000			160,00 €
	5/8"-10 ARMUE 2200.4.3	220 Cm 12'li	13,69	1.164	999	2.200			176,00 €
	5/8"-10 ARMUE 2500.4.3	250 Cm 12'li	15,64	1.330	1142	2.500			200,00 €
	5/8"-10 ARMUE 2700.4.3	270 Cm 12'li	16,95	1.441	1237	2.700			216,00 €
	5/8"-10 ARMUE 3000.4.3	300 Cm 12'li	18,90	1.607	1380	3.000			240,00 €
10 mm	5/8"-10 ARMUE 7500.5.3	75 Cm 15'li	5,30	450	387	750	150	280	75,00 €
	5/8"-10 ARMUE 1000.5.3	100 Cm 15'li	7,33	623	535	1.000			100,00 €
	5/8"-10 ARMUE 1200.5.3	120 Cm 15'li	8,96	762	654	1.200			120,00 €
	5/8"-10 ARMUE 1500.5.3	150 Cm 15'li	11,41	970	833	1.500			150,00 €
	5/8"-10 ARMUE 1700.5.3	170 Cm 15'li	13,04	1.108	952	1.700			170,00 €
	5/8"-10 ARMUE 2000.5.3	200 Cm 15'li	15,48	1.316	1130	2.000			200,00 €
	5/8"-10 ARMUE 2200.5.3	220 Cm 15'li	17,11	1.454	1249	2.200			220,00 €
	5/8"-10 ARMUE 2500.5.3	250 Cm 15'li	19,56	1.662	1428	2.500			250,00 €
	5/8"-10 ARMUE 2700.5.3	270 Cm 15'li	21,18	1.801	1547	2.700			270,00 €
	5/8"-10 ARMUE 3000.5.3	300 Cm 15'li	23,63	2.008	1725	3.000			300,00 €
10 mm	5/8"-10 ARMUE 750.6.3	75 Cm 18'li	6,36	540	464	750	150	336	90,00 €
	5/8"-10 ARMUE 1000.6.3	100 Cm 18'li	8,80	748	643	1.000			120,00 €
	5/8"-10 ARMUE 1200.6.3	120 Cm 18'li	10,76	914	785	1.200			144,00 €
	5/8"-10 ARMUE 1500.6.3	150 Cm 18'li	13,69	1.164	999	1.500			180,00 €
	5/8"-10 ARMUE 1700.6.3	170 Cm 18'li	15,64	1.330	1142	1.700			204,00 €
	5/8"-10 ARMUE 2000.6.3	200 Cm 18'li	18,58	1.579	1356	2.000			240,00 €
	5/8"-10 ARMUE 2200.6.3	220 Cm 18'li	20,53	1.745	1499	2.200			264,00 €
	5/8"-10 ARMUE 2500.6.3	250 Cm 18'li	23,47	1.995	1713	2.500			300,00 €
	5/8"-10 ARMUE 2700.6.3	270 Cm 18'li	25,42	2.161	1856	2.700			324,00 €
	5/8"-10 ARMUE 3000.6.3	300 Cm 18'li	28,36	2.410	2070	3.000			360,00 €

\* ARMUE 5/8" -10mm 2 Sıralı MARKET ÜST SOĞUTUCULAR Metre Fiyatları 6,66 €

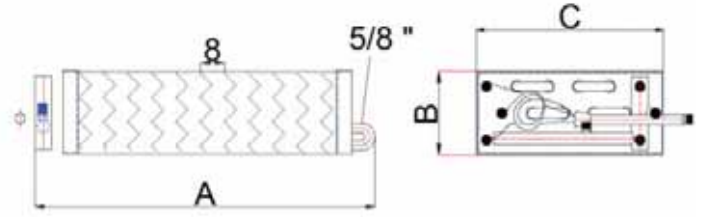

### 8 ARMUE SERİSİ MARKET ÜST EVAPORATÖR 8 ARMUE SERIES GRAVITY COLLERS FOR SHOP WINDOWS

Lamel Aralığı Fin Spacing	KOD CODE	MODEL MODEL	Isı Transfer Alanı Heat Transfer Area	Kapasite Capacity (R 404 A)		Boyutlar Dimension			Fiyat Price €	
				m <sup>2</sup>	Watt	kcal/h	A	B		C
							mm	mm		mm
<b>5648-1/2"</b>										
8 mm	5/8"-8 ARMUE 750.3.3	75 Cm 9'lu	3,97	338	290	750	150	170	45,94 €	
	5/8"-8 ARMUE 1000.3.3	100 Cm 9'lu	5,50	467	402	1.000			61,25 €	
	5/8"-8 ARMUE 1200.3.3	120 Cm 9'lu	6,72	571	491	1.200			73,50 €	
	5/8"-8 ARMUE 1500.3.3	150 Cm 9'lu	8,56	727	625	1.500			91,88 €	
	5/8"-8 ARMUE 1700.3.3	170 Cm 9'lu	9,78	831	714	1.700			104,13 €	
	5/8"-8 ARMUE 2000.3.3	200 Cm 9'lu	11,61	987	848	2.000			122,50 €	
	5/8"-8 ARMUE 2200.3.3	220 Cm 9'lu	12,83	1.091	937	2.200			134,75 €	
	5/8"-8 ARMUE 2500.3.3	250 Cm 9'lu	14,67	1.247	1071	2.500			153,13 €	
	5/8"-8 ARMUE 2700.3.3	270 Cm 9'lu	15,89	1.351	1160	2.700			165,38 €	
	5/8"-8 ARMUE 3000.3.3	300 Cm 9'lu	17,72	1.506	1294	3.000			183,75 €	
8 mm	5/8"-8 ARMUE 750.4.3	75 Cm 12'li	5,30	450	387	750	150	224	61,25 €	
	5/8"-8 ARMUE 1000.4.3	100 Cm 12'li	7,33	623	535	1.000			81,67 €	
	5/8"-8 ARMUE 1200.4.3	120 Cm 12'li	8,96	762	654	1.200			98,00 €	
	5/8"-8 ARMUE 1500.4.3	150 Cm 12'li	11,41	970	833	1.500			122,50 €	
	5/8"-8 ARMUE 1700.4.3	170 Cm 12'li	13,04	1.108	952	1.700			138,83 €	
	5/8"-8 ARMUE 2000.4.3	200 Cm 12'li	15,48	1.316	1130	2.000			163,33 €	
	5/8"-8 ARMUE 2200.4.3	220 Cm 12'li	17,11	1.454	1249	2.200			179,67 €	
	5/8"-8 ARMUE 2500.4.3	250 Cm 12'li	19,56	1.662	1428	2.500			204,17 €	
	5/8"-8 ARMUE 2700.4.3	270 Cm 12'li	21,18	1.801	1547	2.700			220,50 €	
	5/8"-8 ARMUE 3000.4.3	300 Cm 12'li	23,63	2.008	1725	3.000			245,00 €	
8 mm	5/8"-8 ARMUE 7500.5.3	75 Cm 15'li	6,62	563	483	750	150	280	76,56 €	
	5/8"-8 ARMUE 1000.5.3	100 Cm 15'li	9,17	779	669	1.000			102,08 €	
	5/8"-8 ARMUE 1200.5.3	120 Cm 15'li	11,20	952	818	1.200			122,50 €	
	5/8"-8 ARMUE 1500.5.3	150 Cm 15'li	14,26	1.212	1041	1.500			153,13 €	
	5/8"-8 ARMUE 1700.5.3	170 Cm 15'li	16,30	1.385	1190	1.700			173,54 €	
	5/8"-8 ARMUE 2000.5.3	200 Cm 15'li	19,35	1.645	1413	2.000			204,17 €	
	5/8"-8 ARMUE 2200.5.3	220 Cm 15'li	21,39	1.818	1562	2.200			224,58 €	
	5/8"-8 ARMUE 2500.5.3	250 Cm 15'li	24,44	2.078	1785	2.500			255,21 €	
	5/8"-8 ARMUE 2700.5.3	270 Cm 15'li	26,48	2.251	1934	2.700			275,63 €	
	5/8"-8 ARMUE 3000.5.3	300 Cm 15'li	29,54	2.511	2157	3.000			306,25 €	
8 mm	5/8"-8 ARMUE 750.6.3	75 Cm 18'li	7,94	675	580	750	150	336	91,88 €	
	5/8"-8 ARMUE 1000.6.3	100 Cm 18'li	11,00	935	803	1.000			122,50 €	
	5/8"-8 ARMUE 1200.6.3	120 Cm 18'li	13,44	1.143	982	1.200			147,00 €	
	5/8"-8 ARMUE 1500.6.3	150 Cm 18'li	17,11	1.454	1249	1.500			183,75 €	
	5/8"-8 ARMUE 1700.6.3	170 Cm 18'li	19,56	1.662	1428	1.700			208,25 €	
	5/8"-8 ARMUE 2000.6.3	200 Cm 18'li	23,22	1.974	1696	2.000			245,00 €	
	5/8"-8 ARMUE 2200.6.3	220 Cm 18'li	25,67	2.182	1874	2.200			269,50 €	
	5/8"-8 ARMUE 2500.6.3	250 Cm 18'li	29,33	2.493	2142	2.500			306,25 €	
	5/8"-8 ARMUE 2700.6.3	270 Cm 18'li	31,78	2.701	2320	2.700			330,75 €	
	5/8"-8 ARMUE 3000.6.3	300 Cm 18'li	35,44	3.013	2588	3.000			367,50 €	

\* ARMUE 5/8" -10mm 3 Sıralı MARKET ÜST SOĞUTUCULAR Metre Fiyatları 6,8 €

# TİCARİ TİP KONDANSERLER

## COMMERCIAL TYPE CONDENSERS

### TEKNİK BİLGİLER

#### TECHNICAL SPECIFICATIONS

Ticari Tip Kondanserlerimizin kapasiteleri 0,60 kW ile 100 kW arasında değişmektedir.

Our commercial type condensers capacity range is between 0,60 kW and 100 kW

ÜRÜNLER:  
PRODUCTS:

*Ticari Seri Hava Soğutmalı Kondanserlerimiz:*  
*Series Commercial air cooled Condenser*

		Fan Diameter
Aras Ticari Kondanser	ARTK	Ø 200- Ø 300
Aras Alçak Seri Ticari Kondanser	ARASTK	Ø 200- Ø 300
Aras Ticari Seri Kondanserler	ARSK	Ø 300- Ø 500

**Boru/Tubes:** Bakır Borular 3/8".Giriş - Çıkış kollektör malzemesi bakırdır.  
Coppers Tubes 3/8". Header inlet and outlet tube connections made of copper.

**Kalıp geometrisi:** 32x28  
(Mould Geometry):

**Fin:** Finler 100-150 mikron kalınlığında Alüminyumdan dalgalı olarak imal edilmektedir.  
Fins: Fins has been manufactured corrugated 100-150 micron Aluminium

**Kasetleme:** Dış çerçeve galvanizli çelikten imal edilir.  
Casing Supporting structure is made of galvanized sheet.

**Boya:** ARTK, ARASTK ve ARSK serileri boyasızdır. Boya istenildiğinde % 7 Fiyat Farkı alınır.Standart boya rengi RAL7035  
Painted: ARTK,ARASTK and ARSK SERIES not painted.Painted will be % 7 of the difference.Color standart RAL 7035

**Test:** Test basıncı 28 bardır. ARSK Serileri 3 bar azot ile basınçlandırılarak sevk edilir.  
All coils are tested with perssurized 28 bars. ARSK Series are provided with 3 bars nitrogen loaded in

**Fan:** Kondanserlerimiz standart olarak fansız satışa sunulmaktadır. Fanlı istekler için özel fiyatlandırılır.  
Condensers provided without fans.The special orders produced with 200 - 500 mm diameter fans

ADLANDIRMA/CLASSIFICATION:

## ARSK 45235-180

Model /Model	: ARSK
Fan Çapı/Fan diameter	: Ø 450
Fan Sıra Sayısı/Rows of Fans	: 2
Sıradaki Fan Sayısı/Number of Fans per row	: 3
Hatve/Fin Spacing	: 5= 2,5 mm
Yüzey Alanı/Surface	: 180 m <sup>2</sup>

# TİCARİ TİP KONDANSERLER

## COMMERCIAL TYPE CONDENSERS

### TEKNİK BİLGİLER

#### TECHNICAL SPECIFICATIONS

EUROVENT STANDART (EN 327)

Soğutucu Akışkan/Refrigerant	R404 A
Hava Giriş/Air inlet Temp.	30 °C
Kondenzasyon Sıcaklığı/Condensing Temp.	45 °C
Rakım/Altitude	m

Kataloğumuzda vermiş olduğumuz kapasite değerleri R404A Gazı için Eurovent Standart Şartları (EN 327) kabul edilerek hesaplanmıştır. Standart şartların dışında kullanılması halinde belirtilen düzeltme faktörleri kullanılarak katalog değerlerimize uyarlanır.

Capacities given in our catalogue are calculated according to with R404 A gaz end Eurovent (EN 327) conditions. If the gaz, fin material or temperature values are different, selection can be adopted by utilizing different corrections factors and by obtaining capacities in terms of catalogue

Not 1: Eğer kompresör Motor gücü biliniyorsa: Düzeltme faktörü aşağıdaki gibi düzenlenir:

Note 1: If the motor power is known. Correction factor formula is aranged like given below

$$Q \text{ katalog} = (Q+N) \times f2 \times f3 / ( f4 \times f5 \times f6)$$

Not 2: Eğer kompresör Motor gücü bilinmiyorsa: Düzeltme faktörü aşağıdaki gibi düzenlenir:

Note 1: If the motor power is not known. Correction factor formula is aranged like given below

$$Q \text{ katalog} = (Q \times f1 \times f2 \times f3 / ( f4 \times f5 \times f6)$$

Q= Kompresör Soğutma Kapasitesi /Condenser capacity (Catalogue value)

N=Kompresör Motor Gücü /Compressor motor Power

Düzeltilme Faktörleri / Correction Factors:

**f1 Açık Kompresör /Open Compressors:**

Evaporasyon Sıcaklığı Evaporation Temperature	Kondenzasyon Sıcaklığı Condensing Temperature						
	30 °C	35 °C	40 °C	45 °C	50 °C	55 °C	60 °C
-35 °C	1,36	1,41	1,44	-	-	-	-
-30 °C	1,31	1,36	1,4	1,44	-	-	-
-25 °C	1,27	1,32	1,36	1,41	1,45	-	-
-20 °C	1,24	1,28	1,31	1,35	1,39	1,44	-
-15 °C	1,2	1,24	1,27	1,31	1,35	1,39	1,44
-10 °C	1,18	1,21	1,24	1,27	1,31	1,35	1,4
-5 °C	1,15	1,18	1,21	1,24	1,27	1,31	1,36
0 °C	1,13	1,15	1,18	1,21	1,24	1,27	1,31
5 °C	1,1	1,13	1,15	1,18	1,21	1,24	1,28
10 °C	1,08	1,11	1,13	1,15	1,17	1,21	1,24



# TİCARİ TİP KONDANSERLER

## COMMERCIAL TYPE CONDENSERS

### TEKNİK BİLGİLER

#### TECHNICAL SPECIFICATIONS

EUROVENT STANDART (EN 327)

#### f1 Hermetik & Yarı Hermetik Kompresör /Hermetic & Semi Hermetic Compressors:

Evaporasyon Sıcaklığı Evaporation Temperature	Kondenzasyon Sıcaklığı Condensing Temperature						
	30 °C	35 °C	40 °C	45 °C	50 °C	55 °C	60 °C
-40 °C	1,64	1,69	1,76	1,86	2,03	-	-
-35 °C	1,56	1,61	1,66	1,73	1,83	-	-
-30 °C	1,48	1,53	1,57	1,62	1,69	-	-
-25 °C	1,42	1,46	1,5	1,54	1,6	1,68	-
-20 °C	1,37	1,4	1,44	1,48	1,53	1,6	-
-15 °C	1,32	1,35	1,38	1,43	1,48	1,53	1,58
-10 °C	1,28	1,31	1,34	1,37	1,42	1,46	1,52
-5 °C	1,23	1,26	1,29	1,33	1,37	1,41	1,45
0 °C	1,2	1,22	1,25	1,28	1,32	1,36	1,39
5 °C	1,16	1,19	1,21	1,24	1,28	1,31	1,34
10 °C	1,13	1,15	1,18	1,21	1,23	1,26	1,29

#### f2 ΔT Düzeltme Faktörü

f2 ΔT Correction Factor

$$f2 = 15 / \Delta T$$

#### f3 Hava Giriş Sıcaklığı Faktörü

f3 Air Inlet temperature factor

°C	15	20	25	30	35	40	45	50
	0,97	0,98	1	1,02	1,04	1,06	1,08	1,1

#### f4 Deniz Seviyesinden Yükseklik / Height above sea level

f4 Rakım /Altitude	0	500	1000	1500	2000	2500
	1,00	0,97	0,94	0,91	0,88	0,85

#### f5 Soğutucu Faktörü

f5 Refrigerant factor

R404 A	1,00
R22	0,96
R407C	0,87
R134A	0,93
R507	1,00

#### f6 Lamel Malzemesi Düzeltme Faktörü

f6 Fin material correction factor

Aluminyum Aluminium	Kaplı Aluminyum Coated Aluminium	Bakır Copper
1,00	0,97	1,03

# TİCARİ TİP KONDANSERLER

## COMMERCIAL TYPE CONDENSERS

### TEKNİK BİLGİLER

#### TECHNICAL SPECIFICATIONS

#### Düzeltilme Faktörlerinin Kullanılması

The use of correction factors

$$Q \text{ Katalog} = ( Q \times f_1 \times f_2 \times f_3 ) / ( f_4 \times f_5 \times f_6 )$$

**Kompresör Kapasitesi** **Q = 80000W**  
Refrigerating Capacity of Compressor:

**Kompresör tipi** **Yarı Hermetik**  
Compressor Type Semi Hermetic

**Evaporasyon Sıcaklığı** **t evap= -10 °C**  
Evaporation Temperature t evap= -10 °C

**Kondenzasyon Sıcaklığı** **t kond= 45 °C**  
Condensing Temperature t cond.= 40 °C

**Hava Giriş Sıcaklığı** **ta = 30 °C**  
Air inlet Temperature ta = 30 °C

**Soğutucu Akışkan** **R404A**  
Refrigerant R404A

**Lamel Malzemesi** **Alüminyum**  
Fin Material Aluminium

**Rakım** **1000 m**  
Altitude 1000 m

$$\Delta T = t \text{ kond} - t_a = (45) - (30) = 15 \text{ °C}$$
$$\Delta T = t \text{ cond} - t_a = (45) - (30) = 15 \text{ °C}$$

**Kompresör Düzeltme faktörü** **f1=1,34**  
Compressor Correction Factor f1=1,34

**ΔT Düzeltme Faktörü** **f2=1,00**  
ΔT Correction Factor f2=1,00

**Hava Giriş Sıcaklığı Faktörü** **f3=1,02**  
Air Inlet Temp. Factor f3=1,02

**Rakım Faktörü** **f4=0,94**  
AltitudeFactor f4=0,94

**Soğutucu Faktörü** **f5=1,00**  
Refrigerant Factor f5=1,00

**Lamel Malzemesi Faktörü** **f6=1,00**  
Fin Material Factor f6=1,00

$$Q \text{ Katalog} = ( Q \times f_1 \times f_2 \times f_3 ) / ( f_4 \times f_5 \times f_6 )$$

$$Q \text{ Katalog} = (80.000 \times 1,34 \times 1,00 \times 1,02) / (0,94 \times 1,00) \times 1,00$$

$$Q \text{ Katalog} = 116.323 \text{ W}$$

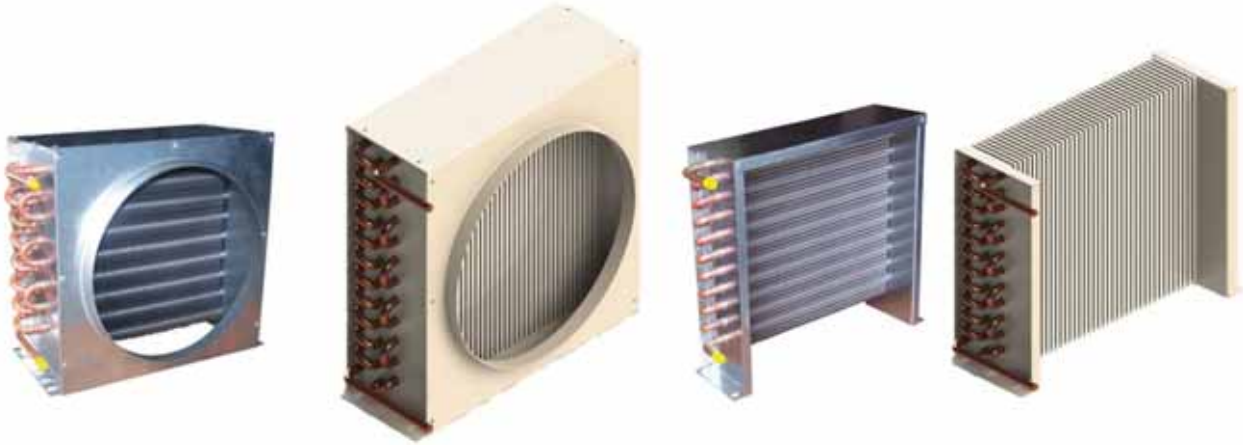
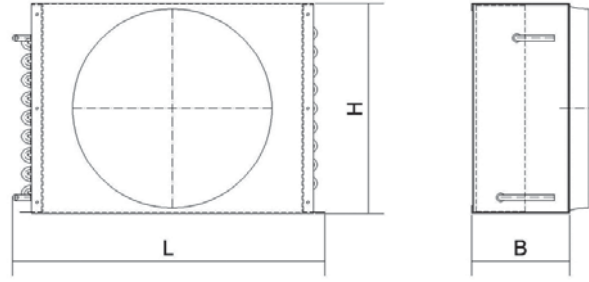

### ARSBTK TİCARİ SERİ HAVA SOĞUTMALI KONDANSERLER

ARSBTK SERIES COMMERCIAL AIR COOLED CONDENSER

Lamel Aralığı Fin Spacing	MODEL MODEL	Yüzey Surface		Kapasite Capacity (R 404 A)		Fan		Bağlantılar Connection		Boyutlar Dimension			Fiyat Price	
		m <sup>2</sup>	Watt	kcal/h	Çap Ø Diameter mm	Debi Flow m <sup>3</sup> /h	Giriş Ø Inlet mm	Çıkış Ø Outlet mm	L mm	H mm	B mm	Davlumbazsız Without Diffuser €	Davlumbazlı With Diffuser €	
<b>2522-3/8"</b>														
3,5 mm Havte / Fin Spacing	ARSBTK 1/5 HP- 1/5 HP 20D	1,26	620	533	1x200	420	10	10	330	225	70	15,00 €	20,00 €	
	ARSBTK 1/4 HP- 1/4 HP 20D	1,45	715	615	1x200	420	10	10	330	270	100	18,00 €	22,00 €	
	ARSBTK 1/4 HP- 1/4 HP 25D	1,45	970	834	1x250	680	10	10	330	270	100	18,00 €	22,00 €	
	ARSBTK 1/3 HP- 1/3 HP 25D	2,04	1285	1105	1x250	680	10	10	375	320	100	22,00 €	26,00 €	
	ARSBTK 1/2 HP- 1/2 HP 25D	3,06	1665	1432	1x250	680	10	10	375	320	120	29,00 €	33,00 €	
	ARSBTK 3/4 HP- 3/4 HP 25D	3,67	1860	1600	1x250	680	12	12	410	320	120	37,00 €	42,00 €	
	ARSBTK 3/4 HP- 3/4 HP 30D	3,67	2040	1754	1x300	1100	12	12	410	320	120	37,00 €	42,00 €	
	ARSBTK 1/1 HP- 1/1 HP 25D	4,90	2165	1862	1x250	680	12	12	410	320	145	47,00 €	51,00 €	
	ARSBTK 1/1 HP- 1/1 HP 30D	4,90	2480	2133	1x300	1100	12	12	410	320	145	47,00 €	51,00 €	
	ARSBTK 1/1 HP 20ÇD	6,12	2890	2385	2x200	840	16	12	680	295	145	52,00 €	61,00 €	
	ARSBTK 1,5 HP- 1,5 HP 30D	5,94	3190	2743	1x300	1100	12	12	480	330	160	55,00 €	58,00 €	
	ARSBTK 1,5 HP 25ÇD	8,17	3380	2907	2x250	1360	16	12	680	295	160	67,00 €	76,00 €	
	ARSBTK 2 HP- 2 HP 30D	8,23	3724	3203	1x300	1100	16	12	460	360	165	69,00 €	75,00 €	

### ARSBTK TİCARİ SERİ HAVA SOĞUTMALI KONDANSERLER

ARSBTK SERIES COMMERCIAL AIR COOLED CONDENSER

<b>2522-3/8"</b>													
3,2 mm Havte / Fin Spacing	ARSBTK 1/5 HP- 1/5 HP 20D	1,38	620	533	1x200	420	10	10	330	225	70	15,50 €	20,50 €
	ARSBTK 1/4 HP- 1/4 HP 20D	1,58	840	722	1x200	420	10	10	330	270	100	18,50 €	22,50 €
	ARSBTK 1/3 HP- 1/3 HP 20D	2,23	1070	919	1x200	420	10	10	375	320	100	22,50 €	27,00 €
	ARSBTK 1/2 HP- 1/2 HP 20D	3,35	1430	1228	1x200	420	10	10	375	320	120	29,50 €	34,00 €
	ARSBTK 3/4 HP- 3/4 HP 25D	4,02	1810	1555	1x250	680	12	12	410	320	120	38,00 €	43,00 €
	ARSBTK 3/4 HP 30D	4,02	2010	1727	2x200	840	12	12	410	320	120	38,00 €	43,00 €
	ARSBTK 1/1 HP- 1/1 HP 25D	5,36	2120	1821	1x250	680	12	12	410	320	145	48,00 €	52,00 €
	ARSBTK 1/1 HP 20ÇD	6,70	2840	2440	2x200	840	16	12	680	295	145	53,00 €	62,00 €
	ARSBTK 1,5 HP-1,5 HP 30D	6,50	3230	2775	1x300	1100	12	12	480	330	160	55,50 €	58,50 €
	ARSBTK 1,5 HP 25ÇD	8,93	3350	2878	2x250	1360	16	12	680	295	160	68,00 €	77,00 €
	ARSBTK 2 HP-2HP 30D	9,00	3710	3187	1x300	1100	16	12	460	360	165	70,00 €	76,00 €

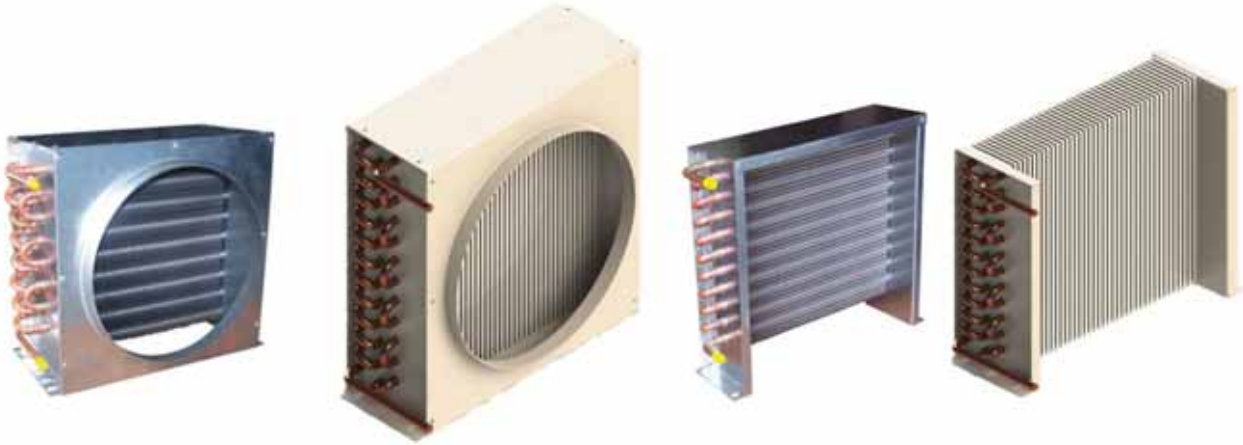
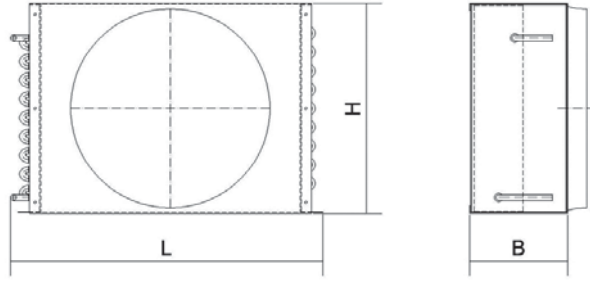

### TİCARİ SERİ HAVA SOĞUTMALI KONDANSERLER

SERIES COMMERCIAL AIR COOLED CONDENSER

Lamel Aralığı Fin Spacing	MODEL MODEL	Yüzey Surface		Kapasite Capacity (R 404 A)		Fan		Bağlantılar Connection		Boyutlar Dimension			Fiyat Price	
		m <sup>2</sup>	Watt	kcal/h	Çap Ø Diameter mm	Debi Flow m <sup>3</sup> /h	Giriş Ø Inlet mm	Çıkış Ø Outlet mm	L mm	H mm	B mm	Davlumbazsız Without Diffuser €	Davlumbazlı With Diffuser €	
<b>3228-3/8"</b>														
3,5 mm Havte / Fin Spacing	ARTK 1 5 HP- 1 5 HP 20D	1,52	610	524	1x200	420	10	10	330	230	90	13,00 €	21,00 €	
	ARTK 1 4 HP- 1 4 HP 20D	1,77	690	593	1x200	420	10	10	330	240	100	15,00 €	22,00 €	
	ARTK 1 3 HP- 1 3 HP 25D	2,74	1245	1069	1x250	680	10	10	380	320	120	19,00 €	28,00 €	
	ARTK 1 2 HP- 1 2 HP 25D	4,10	1670	1435	1x250	680	10	10	380	320	140	28,00 €	35,00 €	
	ARTK 3 4 HP- 3 4 HP 25D	5,02	1825	1568	1x250	680	12	12	410	340	140	35,00 €	43,00 €	
	ARTK 3 4 HP- 3 4 HP 30D	5,02	1985	1705	1x300	1100	12	12	410	340	140	35,00 €	43,00 €	
	ARTK 1 1 HP- 1 1 HP 25D	6,69	2230	1916	1x250	680	12	12	410	340	165	44,00 €	52,00 €	
	ARTK 1 1 HP- 1 1 HP 30D	6,69	2580	2216	1x300	1100	12	12	410	340	165	44,00 €	52,00 €	
	ARTK 1 1 HP 25 D	9,30	3020	2594	2x250	1360	16	12	690	300	165	55,00 €	68,00 €	
	ARTK 1 5 HP- 1 5 HP 30D	7,70	3210	2757	1x300	1100	12	12	460	340	175	48,00 €	57,00 €	
	ARTK 1 5 HP 25 D	9,73	3420	2938	2x250	1360	16	12	730	340	165	57,00 €	71,00 €	
ARTK 2 HP- 2 HP 30D	9,73	3710	3187	1x300	1100	16	12	480	400	185	60,00 €	72,00 €		

### TİCARİ ALÇAK SERİ HAVA SOĞUTMALI KONDANSERLER

SHORT SERIES COMMERCIAL AIR COOLED CONDENSER

Lamel Aralığı Fin Spacing	MODEL MODEL	Yüzey Surface		Kapasite Capacity (R 404 A)		Fan		Bağlantılar Connection		Boyutlar Dimension			Fiyat Price	
		m <sup>2</sup>	Watt	kcal/h	Çap Ø Diameter mm	Debi Flow m <sup>3</sup> /h	Giriş Ø Inlet mm	Çıkış Ø Outlet mm	L mm	H mm	B mm	Davlumbazsız Without Diffuser €	Davlumbazlı With Diffuser €	
<b>3228-3/8"</b>														
3,2 mm Havte / Fin Spacing	ARASTK 1/4 HP- 1/4 HP 20D	2,02	840	722	1x200		10	10	330	245	100	15,00 €	23,00 €	
	ARASTK 1/3 HP- 1/3 HP 20D	3,03	1070	919	1x200		10	10	330	245	125	20,00 €	28,00 €	
	ARASTK 1/2 HP- 1/2 HP 20D	4,03	1430	1228	1x200		10	10	330	245	150	26,00 €	33,00 €	
	ARASTK 3/4 HP- 3/4 HP 25D	5,85	1810	1555	1x250		12	12	410	275	150	37,00 €	45,00 €	
	ARASTK 3/4 HP 20ÇD	5,82	2010	1727	2x200		12	12	575	245	125	39,00 €	49,00 €	
	ARASTK 1/1 HP- 1/1 HP 25D	7,32	2120	1821	1x250		12	12	410	275	180	44,00 €	52,00 €	
	ARASTK 1/1 HP 20ÇD	8,69	2840	2440	2x200		16	12	635	245	150	50,00 €	62,00 €	
	ARASTK 1,5 HP-1,5 HP 30DD	8,42	3230	2775	1x300		12	12	460	330	150	48,00 €	57,00 €	
	ARASTK 1,5 HP 25ÇD	11,00	3350	2878	2x250		16	12	695	275	150	62,00 €	73,00 €	
	ARASTK 2 HP-2HP 30D	11,08	3710	3187	1x300		16	12	480	330	180	61,00 €	70,00 €	
	ARASTK 2,5 HP 25ÇD	15,46	4370	3754	2x250		16	12	695	295	180	77,00 €	91,00 €	

**TİCARİ SERİ HAVA SOĞUTMALI STANDART KONDANSERLER**  
SERIES COMMERCIAL AIR COOLED STANDART CONDENSER

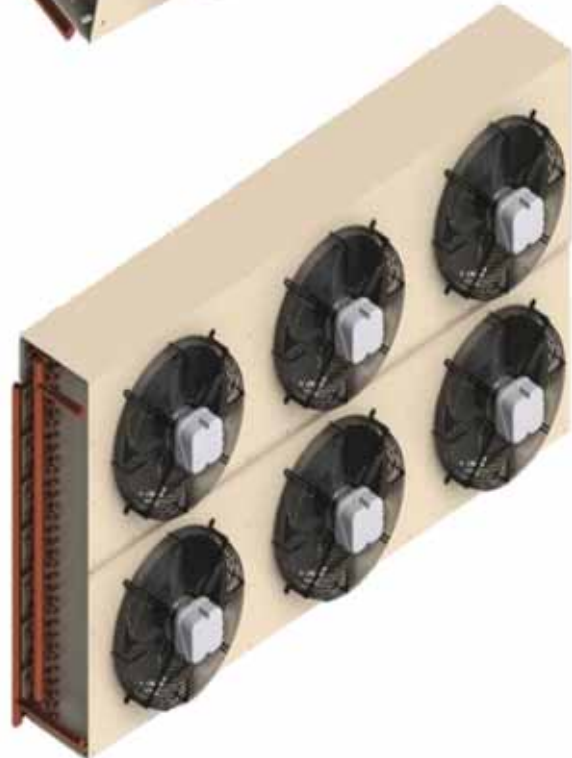
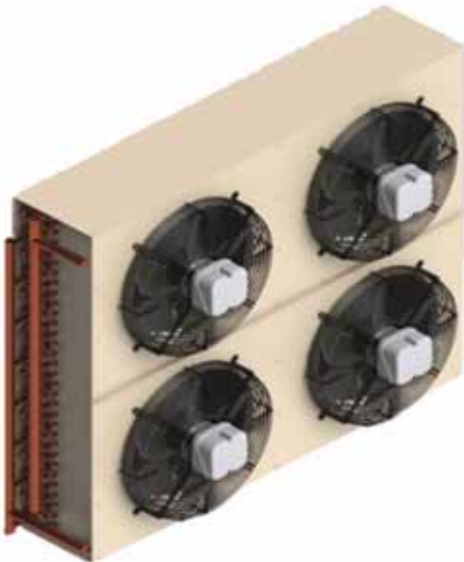
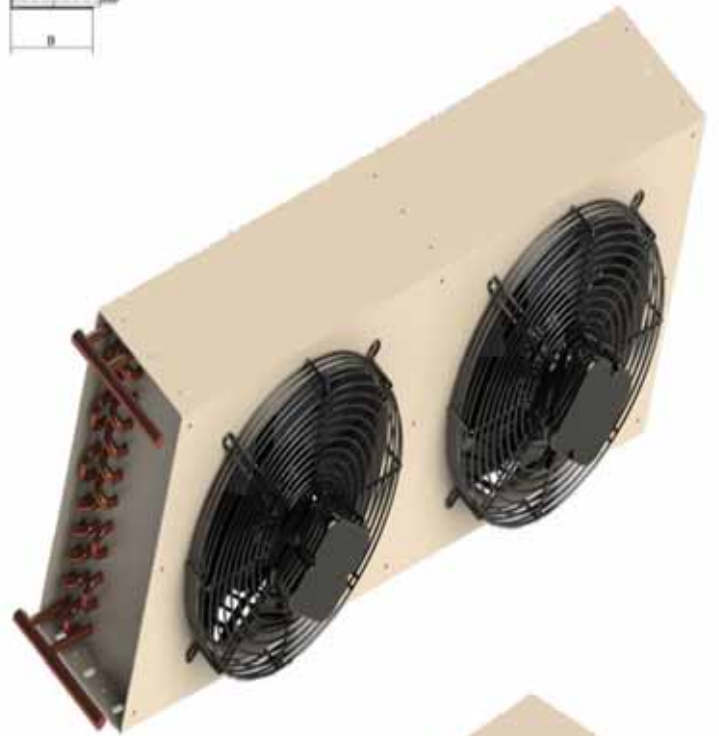
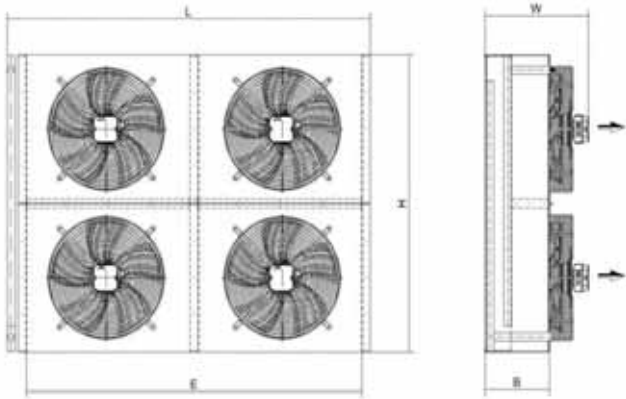
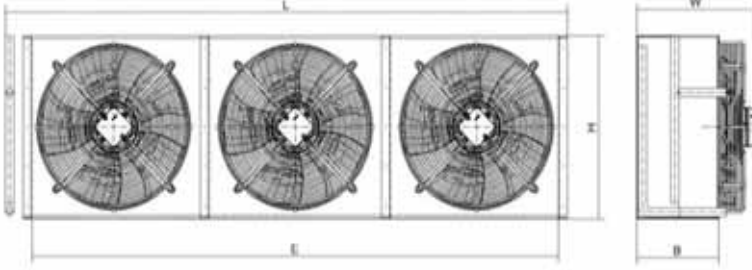

**ARSBK TİCARİ SERİ HAVA SOĞUTMALI KONDANSERLER**  
ARSBK SERIES COMMERCIAL AIR COOLED CONDENSER

Lamel Aralığı Fin Spacing	MODEL MODEL	Yüzey Surface	Kapasite Capacity (R 404 A)		Fan		Bağlantılar Connection		Boyutlar Dimension			Fiyat Price
					Çap Ø Diameter	Debi Flow	Giriş Ø İnlet	Çıkış Ø Outlet	L	H	B	
					mm	m³/h	mm	mm	mm	mm	mm	

2522-3/8"												
2,1 mm Hatve / Fin Spacing	ARSBK 3011-006	6,60	3227	2772	1x300	1565	16	12	490	420	150	50,00 €
	ARSBK 3511-006	6,60	3971	3411	1x350	2252	16	12	490	420	150	50,00 €
	ARSBK 3511-010	10,52	5345	4591	1x350	2684	16	12	610	520	150	68,00 €
	ARSBK 3511-015	15,84	6781	5825	1x350	2487	19	16	740	420	170	89,00 €
	ARSBK 3511-020	21,11	7408	6363	1x350	2318	19	16	740	420	190	111,00 €
	ARSBK 3511-021	21,34	7977	6852	1x350	2724	19	16	800	520	190	116,00 €
	ARSBK 4011-023	23,38	10289	8838	1x400	3828	22	16	730	620	190	130,00 €
	ARSBK 3521-025	25,05	11691	10043	2x350	4494	19	16	990	470	190	135,00 €
	ARSBK 3511-028	28,45	8938	7678	1x350	2601	22	16	800	520	190	145,00 €
	ARSBK 4011-030	29,94	11357	9756	1x400	3528	22	19	770	570	210	157,00 €
	ARSBK 4011-031	31,18	11625	9986	1x400	3592	22	19	730	620	210	164,00 €
	ARSBK 4021-032	32,17	16321	14020	2x400	6494	28	22	1150	520	210	177,00 €
	ARSBK 4511-033	32,91	13038	11200	1x450	4784	28	22	870	720	210	180,00 €
	ARSBK 3521-033	33,40	13042	11203	2x350	4099	22	19	990	470	210	172,00 €
	ARSBK 4011-040	41,55	12487	10726	1x400	3483	22	19	725	670	230	213,00 €
	ARSBK 4021-042	42,89	18047	15502	2x400	5873	28	22	1050	520	210	217,00 €
	ARSBK 4521-044	43,79	21682	18625	2x450	8487	28	22	1290	620	210	227,00 €
	ARSBK 4511-044	43,88	15215	13070	1x450	4591	28	22	870	720	230	225,00 €
	ARSBK 5011-048	47,63	19969	17153	1x500	6482	28	22	880	770	230	245,00 €
	ARSBK 5021-052	52,27	27437	23568	2x500	12003	28	22	1410	670	210	266,00 €
	ARSBK 4511-055	54,85	16441	14123	1x450	4412	28	22	870	720	230	268,00 €
	ARSBK 4521-058	58,39	24504	21049	2x450	7884	28	22	1290	620	210	282,00 €
	ARSBK 4521-064	64,95	26643	22886	2x450	9539	28	22	1620	720	210	313,00 €
	ARSBK 5021-070	69,69	31674	27208	2x500	10781	28	22	1410	670	230	336,00 €
ARSBK 4531-086	86,60	36573	31416	3x450	11761	28	22	1860	620	230	400,00 €	
ARSBK 5021-098	97,65	40640	34910	2x500	13123	35	28	1610	820	230	465,00 €	
ARSBK 5021-120	119,18	46244	39724	2x500	14374	35	28	1810	870	230	550,00 €	

2522-3/8"												
2,5 mm Hatve / Fin Spacing	ARSBK 3515-005	5,54	3646	3132	1x350	2333	16	12	500	420	190	51,00 €
	ARSBK 3515-006	6,86	4031	3463	1x350	2530	16	12	580	420	150	55,00 €
	ARSBK 3015-007	7,69	3317	2849	1x300	1193	16	12	455	320	150	58,00 €
	ARSBK 3515-008	8,31	4522	3884	1x350	2061	16	16	500	420	190	65,00 €
	ARSBK 3515-010	10,39	5381	4622	1x350	2304	12	10	570	420	190	72,00 €
	ARSBK 3515-014	14,03	6135	5270	1x350	2138	19	16	550	470	190	94,00 €
	ARSBK 4015-015	15,33	7667	6586	1x400	3570	19	16	670	520	190	103,00 €
	ARSBK 4015-016	16,37	8581	7371	1x400	3683	19	16	800	470	190	106,00 €
	ARSBK 3525-016	16,84	9346	8028	2x350	4122	19	16	910	420	190	112,00 €
	ARSBK 3525-018	19,54	10650	9148	2x350	4471	19	16	1030	420	190	124,00 €
	ARSBK 4015-020	21,51	9121	7835	1x400	3281	22	19	670	520	200	132,00 €
	ARSBK 3525-025	24,94	11180	9604	2x350	3973	22	16	1010	420	190	149,00 €
	ARSBK 4515-025	25,36	10970	9423	1x450	4113	22	19	690	620	220	159,00 €
	ARSBK 4515-028	29,10	12678	10890	1x450	4345	22	19	800	620	220	173,00 €
	ARSBK 4025-030	31,80	12640	10858	2x400	3880	22	19	690	620	250	188,00 €
	ARSBK 4515-030	31,70	15440	13263	1x450	5627	22	16	1120	470	220	186,00 €
	ARSBK 5015-035	37,71	17158	14739	1x500	5490	28	19	750	670	250	223,00 €
	ARSBK 3525-035	36,48	14388	12359	2x350	4825	22	16	920	670	190	208,00 €
	ARSBK 4515-040	41,57	15220	13074	1x450	4800	22	19	910	770	220	235,00 €
	ARSBK 4525-045	46,83	21363	18351	2x450	9353	22	19	1150	670	220	263,00 €
	ARSBK 5015-046	48,71	19310	16587	1x500	6162	22	19	860	770	230	269,00 €
	ARSBK 4525-050	50,71	23570	20247	2x450	8227	22	19	1300	620	220	277,00 €
	ARSBK 4525-060	60,62	25485	21892	2x450	8820	28	22	1360	720	220	331,00 €
	ARSBK 5015-068	69,28	25350	21776	1x500	7267	28	22	1110	820	230	371,00 €
ARSBK 4525-075	77,42	29600	25426	2x450	9443	28	22	1610	770	220	405,00 €	
ARSBK 5025-090	96,30	40400	34704	2x500	12250	35	28	1500	820	230	509,00 €	
ARSBK 5025-110	116,13	45147	38781	2x500	13487	35	22	1610	930	240	597,00 €	
ARSBK 5035-145	153,80	61280	52640	3x500	19008	42	28	2330	820	240	770,00 €	

**ARSBK TİCARİ SERİ HAVA SOĞUTMALI KONDANSERLER**  
ARSBK SERIES COMMERCIAL AIR COOLED CONDENSER

Lamel Aralığı Fin Spacing	MODEL MODEL	Yüzey Surface	Kapasite Capacity (R 404 A)		Fan		Bağlantılar Connection		Boyutlar Dimension			Fiyat Price
					Çap Ø Diameter	Debi Flow	Giriş Ø Inlet	Çıkış Ø Outlet	L	H	B	
					mm	m <sup>3</sup> /h	mm	mm	mm	mm	mm	

**2522-3/8"**

2,8 mm Hatve / Fin Spacing	ARSBK 3518-007	7,42	4279	3676	1x350	2092	16	12	490	420	170	64,00 €
	ARSBK 3518-010	10,02	5525	4746	1x350	2464	16	12	550	470	170	80,00 €
ARSBK 3028-011	10,63	5538	4757	2x300	2428	16	12	785	345	140	82,00 €	
ARSBK 3028-012	12,44	6107	5246	2x300	2678	16	12	810	395	140	94,00 €	
ARSBK 3518-013	12,80	6010	5163	1x350	2170	16	12	540	470	170	95,00 €	
ARSBK 4018-015	15,46	8262	7097	1x400	3320	19	16	570	520	170	114,00 €	
ARSBK 3028-015	15,48	7124	6120	2x300	2653	19	16	810	370	160	113,00 €	
ARSBK 3028-020	20,73	8074	6936	2x300	2549	19	16	810	395	180	141,00 €	
ARSBK 4018-021	21,34	10330	8873	1x400	3820	19	16	690	620	170	147,00 €	
ARSBK 4518-025	25,52	11467	9850	1x450	3756	22	16	645	570	230	172,00 €	
ARSBK 3028-027	26,54	8830	7585	2x300	2477	22	16	810	420	200	174,00 €	
ARSBK 3028-030	31,90	10619	9122	2x300	3250	22	16	920	520	180	200,00 €	
ARSBK 4518-032	32,29	12600	10823	1x450	4520	22	16	675	620	250	211,00 €	
ARSBK 4518-037	37,30	13777	11834	1x450	3925	22	19	765	620	250	236,00 €	
ARSBK 4028-038	38,66	17100	14689	2x400	5602	22	19	1080	520	250	243,00 €	
ARSBK 3528-040	40,36	14110	12120	2x350	3944	22	19	965	520	200	247,00 €	
ARSBK 4528-041	41,20	21200	18211	2x450	8033	22	19	1205	620	220	259,00 €	
ARSBK 4028-041	41,75	16065	13800	2x400	4755	28	19	995	520	210	262,00 €	
ARSBK 3048-042	42,33	16340	14036	2x2x300	5170	28	19	820	770	180	279,00 €	
ARSBK 3548-045	46,01	20900	17953	2x2x350	8278	28	19	940	870	180	300,00 €	
ARSBK 4528-055	54,60	22210	19078	2x450	6576	28	22	1175	570	250	331,00 €	
ARSBK 3548-055	55,21	22450	19285	2x2x350	7465	28	22	910	870	180	348,00 €	
ARSBK 4528-064	64,02	25500	21905	2x450	7260	28	22	1250	620	250	379,00 €	
ARSBK 5028-075	75,39	35550	30537	2x500	10980	35	22	1360	670	250	449,00 €	
ARSBK 5028-082	82,63	35240	30271	2x500	10510	35	22	1460	670	250	484,00 €	
ARSBK 4538-084	84,71	34475	29614	3x450	10081	35	22	1770	570	250	491,00 €	
ARSBK 4538-096	96,87	37760	32436	3x450	10935	35	22	1850	620	250	553,00 €	
ARSBK 5038-113	113,08	53323	45804	3x500	16450	42	28	1990	670	250	651,00 €	
ARSBK 5038-125	124,84	55678	47827	3x500	17045	42	28	2170	670	250	710,00 €	
ARSBK 5048-140	141,73	68012	58422	4x500	21220	42	28	2510	700	250	799,00 €	
ARSBK 5048-153	153,19	69755	59920	2x2x500	21340	42	28	1390	1360	250	897,00 €	
ARSBK 5068-230	229,18	104210	89516	2x3x500	32680	42	28	2010	1360	250	1.270,00 €	

**TİCARİ SERİ HAVA SOĞUTMALI KONDANSERLER**  
SERIES COMMERCIAL AIR COOLED CONDENSER

Lamel Aralığı Fin Spacing	MODEL MODEL	Yüzey Surface	Kapasite Capacity (R 404 A)		Fan		Bağlantılar Connection		Boyutlar Dimension			Fiyat Price  €
					Çap Ø Diameter	Debi Flow	Giriş Ø İnlet	Çıkış Ø Outlet	L	B	H	
					mm	m <sup>3</sup> /h	mm	mm	mm	mm	mm	
<b>3228-3/8"</b>												
2,8 mm Hatve / Fin Spacing	ARSK 3018-006	6,46	2550	2190	1x300	1435	12	10	450	330	160	46,00 €
	ARSK 3018-008	8,61	3120	2680	1x300	1295	12	10	450	330	190	55,00 €
	ARSK 3518-010	10,26	4490	3857	1x350	2290	19	16	560	390	180	64,00 €
	ARSK 3518-012	11,86	4980	4278	1x350	2440	19	16	630	390	180	70,00 €
	ARSK 4018-016	15,81	6900	5927	1x400	3620	19	16	630	520	220	93,00 €
	ARSK 4018-020	21,08	8100	6958	1x400	3245	22	19	630	520	220	116,00 €
	ARSK 4518-025	25,99	10210	8770	1x450	4165	22	19	680	580	250	137,00 €
	ARSK 5018-030	30,55	13660	11734	1x500	5790	22	19	780	580	250	156,00 €
	ARSK 5018-035	36,03	15460	13280	1x500	6360	22	19	900	580	250	176,00 €
	ARSK 4528-040	41,35	17880	15359	2x450	7500	22	19	1140	520	250	199,00 €
	ARSK 4528-045	46,51	19100	16407	2x450	7940	22	19	1140	580	250	220,00 €
	ARSK 4528-050	51,99	21200	18211	2x450	8335	28	22	1265	580	250	245,00 €
	ARSK 5028-064	64,98	28600	24567	2x500	10980	28	22	1265	580	280	298,00 €
	ARSK 5028-072	74,10	30520	26217	2x500	11150	28	22	1425	580	280	330,00 €
	ARSK 4538-076	77,98	31950	27445	3x450	12500	28	22	1835	580	250	347,00 €
	ARSK 5028-086	88,93	33720	28965	2x500	11030	28	22	1425	580	310	384,00 €
	ARSK 5038-0100	102,61	43430	37306	3x500	16620	35	22	1940	580	280	448,00 €
ARSK 5038-0120	123,13	48810	41928	3x500	16410	35	22	1940	580	310	524,00 €	
<b>3228-3/8"</b>												
2,3 mm Hatve / Fin Spacing	ARSK 3513-010	10,55	4.250	3651	1x350	2080	16	12	470	400	170	60,00 €
	ARSK 3513-012	12,49	4520	3883	1x350	2215	16	12	540	400	170	66,00 €
	ARSK 3513-015	15,54	5540	4759	1x350	2450	19	16	570	465	170	79,00 €
	ARSK 4013-020	20,36	8145	6997	1x400	3600	19	16	640	530	190	99,00 €
	ARSK 3523-025	26,23	10610	9114	2x350	4540	19	16	900	465	170	120,00 €
	ARSK 5013-030	31,64	12910	11090	1x500	5020	22	19	665	590	250	146,00 €
	ARSK 5013-035	37,01	14620	12559	1x500	5520	22	19	695	650	250	166,00 €
	ARSK 5013-040	41,64	16020	13761	1x500	5945	22	19	770	650	250	180,00 €
	ARSK 4523-040	40,71	16650	14302	2x450	8135	22	19	1200	530	200	178,00 €
	ARSK 4523-050	52,06	19430	16690	2x450	7350	28	22	1155	530	250	221,00 €
	ARSK 4523-062	63,29	22400	19242	2x450	8080	28	22	1240	600	250	259,00 €
	ARSK 5023-072	74,02	29090	24988	2x500	11040	28	22	1300	660	250	300,00 €
	ARSK 3523-082	83,89	32360	27797	2x500	11930	28	22	1460	660	250	332,00 €
	ARSK 4533-095	95,21	34510	29644	3x450	12130	28	22	1815	600	260	368,00 €
	ARSK 4533-105	105,79	36940	31731	3x450	12680	35	28	1820	660	260	417,00 €
	ARSK 5033-125	126,21	46350	39815	3x500	17930	35	28	1970	730	280	499,00 €
	ARSK 5033-145	146,56	52880	45424	3x500	19440	35	28	2170	730	280	564,00 €
<b>3228-3/8"</b>												
2,5 mm Hatve / Fin Spacing	ARSK 30225-045	45,97	15340	13177	2x2x300	5680	19	16	1000	810	200	228,00 €
	ARSK 30225-061	61,29	16619	14276	2x2x300	5050	22	16	1000	810	200	282,00 €
	ARSK 35225-060	59,59	23607	20278	2x2x350	9600	19	16	1100	910	200	281,00 €
	ARSK 35225-080	79,45	27096	23275	2x2x350	9000	22	16	1100	910	200	350,00 €
	ARSK 40225-082	81,72	33842	29070	2x2x400	14200	22	19	1300	1010	230	379,00 €
	ARSK 40225-109	108,96	38156	32776	2x2x400	12800	28	22	1300	1010	230	488,00 €
	ARSK 45225-108	107,26	41484	35635	2x2x450	16500	28	22	1500	1210	230	485,00 €
	ARSK 45225-143	143,01	47411	40726	2x2x450	15500	35	28	1500	1210	230	631,00 €
	ARSK 50225-137	136,20	54423	46749	2x2x500	22.400	35	28	1720	1350	250	628,00 €
	ARSK 50225-182	181,60	64579	55473	2x2x500	22.000	35	28	1620	1350	250	776,00 €
	ARSK 30235-069	68,95	23226	19951	2x3x300	8520	22	19	1450	810	200	323,00 €
	ARSK 30235-092	91,94	25139	21594	2x3x300	7500	28	22	1450	810	200	410,00 €
	ARSK 35235-090	89,38	31907	27408	2x3x350	12000	28	22	1600	910	200	409,00 €
	ARSK 35235-120	119,18	40825	35069	2x3x350	13500	28	22	1600	910	200	507,00 €
	ARSK 40235-123	122,58	50957	43772	2x3x400	21300	28	22	1900	1010	230	549,00 €
	ARSK 40235-164	163,44	57295	49216	2x3x400	19200	28	22	1900	1010	230	710,00 €
	ARSK 45235-161	160,89	60719	52158	2x3x450	24750	35	28	2220	1210	230	709,00 €
	ARSK 45235-215	214,52	70164	60271	2x3x450	23250	42	35	2220	1210	250	919,00 €
	ARSK 50235-205	204,30	67918	58342	2x3x500	33.600	42	35	2300	1350	250	908,00 €
	ARSK 50235-273	272,40	89989	77301	2x3x500	33.000	42	35	2300	1350	250	1.127,00 €



## AREK ENDÜSTRİYEL SERİ HAVA SOĞUTMALI KONDANSERLER

AREK SERIES INDUSTRIAL AIR COOLED CONDENSER

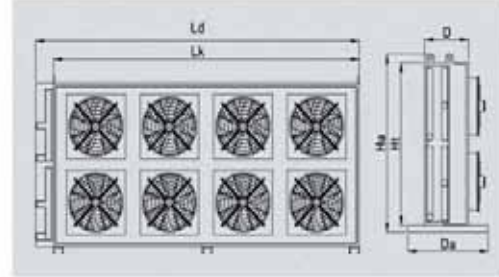
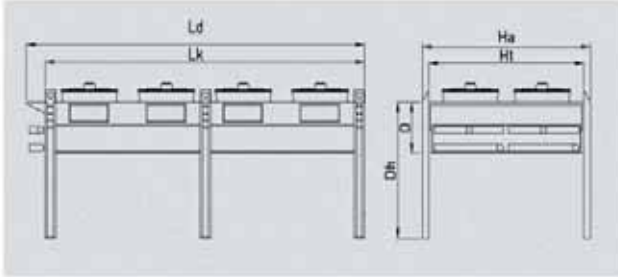

ARAS AREK Serisi Endüstriyel Hava Soğutmalı Kondanserler 15 K sıcaklık aralığında 12,5 Kw- 750 Kw aralığında değişen ürünlerden oluşmaktadır. Tüm modeller yatay ve dikey montaja uygundur. Sipariş esnasında yatay yada dikey kullanılacağı belirtilerek ona uygun taşıyıcı ayaklarla sevk edilmelidir.

Kondanserler için belirtilen kapasite değerleri 25°C ortam sıcaklığı ve 15 K sıcaklık farkında R404A gaz için geçerlidir.

Bataryalarımızda 2,1-2,5 kanat aralığına sahip alüminyum fin ;3/8" ve 1/2" bakır boru kullanılmaktadır. Tüm bataryalarımız 30 Bar basınç değerinde test edilir ve test sonrası 4 Bar pozitif basınç ile sevk edilir

Kondanser kasetleri,korozyona dayanıklı olacak şekildegalvenizli çelik malzemeden üretilir ve elektrostatik toz boya ile boyanır. Ürünlerimizde standart renk olarak RAL 7035 kullanılır.

Fan motorlarına sık kalkış yaptırılmamalıdır (saatte en fazla 6 kalkış yaptırılması tavsiye edilir).Kondanserlerin uzun süre kullanılmayacağı durumlarda motorları, her ay minimum 2 saat çalıştırılmalıdır.

ARAS AREK series industrialair cooled condensers are configured with 15 K temperature differences,the capacity values are changing from 12,5 Kw to 750 Kw.All of the models suitable for vertical and horizontal mountings.

*The specified nominal capacity values are valid for 25°C surrounding temperature,with temperature difference of 15 K for the cooling gas of R404A.*

*In the coils,aluminium fin having 2,1-2,5 mm fin space and the copper tube of 3/8" and 1/2" are used.All of the coils are tested at 30 Bar pressure and they are all delivered with 6 Bar positive pressure*

*Cases of condensers are manufactured with material of galvanized steel being endurable aganist the corrosion and electrostatic powder dyed.In our production, RAL 7035 is used as standart color*

*Frequend startdupsshould not be applicable on the fan motors (recommended maxium 6 startupsin one hour). If condensers not to be used for a long time,the motors should be run at least 2 hours,in one month.*

**AREK ENDÜSTRİYEL SERİ HAVA SOĞUTMALI KONDANSERLER**  
AREK SERIES INDUSTRIAL AIR COOLED CONDENSER

Lamel Aralığı Fin Spacing	MODEL MODEL	Yüzey Surface	Fan Sayısı Number of Fan	1210 rpm 50 Hz-1/230 V 1 Fan için Akım ve Güç değerleri Current and Power rate for 1 Fan I : 3.40 Amp P: 0.77 kW		900 rpm Δ 50 Hz-3/400 V 1 Fan için Akım ve Güç değerleri Current and Power rate for 1 Fan I : 0.74 Amp P: 0.32 kW		640 rpm Y 50 Hz-3/400 V 1 Fan için Akım ve Güç değerleri Current and Power rate for 1 Fan I : 0.41 Amp P: 0.20 kW		Bağlantılar Connections			Boyutlar Dimension			Fiyat Price (Ral/ 7035)
				Kapasite Capacity	Hava Debisi Air Flow	Kapasite Capacity	Hava Debisi Air Flow	Kapasite Capacity	Hava Debisi Air Flow	Giriş (in) Çıkış (Out)	Ld	Ht	D	Da		
2522-3/8"																
3/8"- ARSBEK 5011-A1		39,4	1x1x500	20,5	7848	16,4	5622	13,1	4040	Ø 22/Ø 19	1025	970	340	900	362,00 €	
3/8"- ARSBEK 5011-B1		52,6	1x1x500	23,6	7491	18,5	5357	14,4	3785	Ø 22/Ø 19	1025	970	340	900	414,00 €	
3/8"- ARSBEK 5012-A1		78,9	1x2x500	41,5	15697	33,6	11245	26,7	8080	Ø 28/Ø 22	1775	970	340	900	611,00 €	
3/8"- ARSBEK 5012-B1		105,2	1x2x500	47,8	14984	37,9	10715	29,2	7570	Ø 28/Ø 22	1775	970	340	900	708,00 €	
3/8"- ARSBEK 5013-A1		118,3	1x3x500	63,0	23545	50,5	16867	40,1	12125	Ø 35/Ø 28	2525	970	340	900	869,00 €	
3/8"- ARSBEK 5013-B1		157,7	1x3x500	72,0	22477	56,9	16074	43,8	11357	Ø 35/Ø 28	2525	970	340	900	1.011,00 €	
3/8"- ARSBEK 5014-A1		210,3	1x4x500	83,0	31393	67,2	22489	53,5	16166	Ø 42/Ø 35	3275	970	340	900	1.127,00 €	
3/8"- ARSBEK 5014-B1		210,3	1x4x500	94,5	29968	75,0	21431	58,3	15140	Ø 42/Ø 35	3275	970	340	900	1.315,00 €	
3/8"- ARSBEK 5022-A1		157,7	2x2x500	83,1	31393	67,0	22490	53,3	16165	Ø 35/Ø 28	1775	1830	340	900	1.082,00 €	
3/8"- ARSBEK 5022-B1		210,3	2x2x500	98,5	29968	75,8	21430	58,1	15140	Ø 35/Ø 28	1775	1830	340	900	1.276,00 €	
3/8"- ARSBEK 5023-A1		236,6	2x3x500	125,3	47090	101,0	33374	78,9	24250	Ø 42/Ø 35	2525	1830	340	900	1.534,00 €	
3/8"- ARSBEK 5023-B1		315,5	2x3x500	144,0	44954	113,8	32148	87,5	22715	Ø 42/Ø 35	2525	1830	340	900	1.819,00 €	
3/8"- ARSBEK 5024-A1		315,5	2x4x500	166,4	62786	134,4	44978	106,9	32330	Ø 54/Ø 42	3275	1830	340	900	1.988,00 €	
3/8"- ARSBEK 5024-B1		420,6	2x4x500	188,0	59936	150,0	42862	116,5	30284	Ø 54/Ø 42	3275	1830	340	900	2.363,00 €	
2,1 mm Hatve / Fin Spacing																
2522-3/8"																
3/8"- ARSBEK 5011-A5		33,1	1x1x500	19	7980	15,5	5720	12,5	3950	Ø 22/Ø 19	1025	970	340	900	356,00 €	
3/8"- ARSBEK 5011-B5		44,2	1x1x500	22,2	7659	17,6	5480	13,9	3650	Ø 22/Ø 19	1025	970	340	900	406,00 €	
3/8"- ARSBEK 5012-A5		66,2	1x2x500	38,2	15961	31,2	11445	25,1	7900	Ø 28/Ø 22	1775	970	340	900	599,00 €	
3/8"- ARSBEK 5012-B5		88,3	1x2x500	48,3	15319	36,0	10965	28,1	7300	Ø 28/Ø 22	1775	970	340	900	692,00 €	
3/8"- ARSBEK 5013-A5		99,4	1x3x500	57,2	23942	46,2	17166	37,7	11850	Ø 35/Ø 28	2525	970	340	900	851,00 €	
3/8"- ARSBEK 5013-B5		132,5	1x3x500	67,7	22979	53,8	16450	42,0	10950	Ø 35/Ø 28	2525	970	340	900	988,00 €	
3/8"- ARSBEK 5014-A5		132,5	1x4x500	76,7	31930	62,4	22890	50,2	15800	Ø 42/Ø 35	3275	970	340	900	1.103,00 €	
3/8"- ARSBEK 5014-B5		176,7	1x4x500	88,4	30640	71,4	21930	56,2	14600	Ø 42/Ø 35	3275	970	340	900	1.283,00 €	
3/8"- ARSBEK 5022-A5		132,5	2x2x500	76,7	31380	62,2	22885	50,0	15800	Ø 35/Ø 28	1775	1830	340	900	1.058,00 €	
3/8"- ARSBEK 5022-B5		176,7	2x2x500	90,0	30638	71,2	21930	56,0	14600	Ø 35/Ø 28	1775	1830	340	900	1.245,00 €	
3/8"- ARSBEK 5023-A5		198,7	2x3x500	114,3	47885	92,2	34330	75,5	23700	Ø 42/Ø 35	2525	1830	340	900	1.499,00 €	
3/8"- ARSBEK 5023-B5		265,0	2x3x500	135,2	45960	108,0	32900	84,2	21900	Ø 42/Ø 35	2525	1830	340	900	1.772,00 €	
3/8"- ARSBEK 5024-A5		265,0	2x4x500	153,6	63860	124,7	45775	100,3	31600	Ø 54/Ø 42	3275	1830	340	900	1.940,00 €	
3/8"- ARSBEK 5024-B5		353,3	2x4x500	177,0	61280	142,5	43860	112,2	29200	Ø 54/Ø 42	3275	1830	340	900	2.300,00 €	

**AREK ENDÜSTRİYEL SERİ HAVA SOĞUTMALI KONDANSERLER**

AREK SERIES INDUSTRIAL AIR COOLED CONDENSERS

Lamel Aralığı Fin Spacing	MODEL MODEL	Yüzey Surface	Fan Sayısı Number of Fan	900 rpm 50 Hz-1/230 V		650 rpm $\Delta$ 50 Hz-3/400 V		480 rpm $\gamma$ 50 Hz-3/400 V		Boyutlar Dimension			Fiyat Price (Ral/ 7035)		
				Kapasite Capacity	Hava Debisi Air Flow	Kapasite Capacity	Hava Debisi Air Flow	Kapasite Capacity	Hava Debisi Air Flow	Bağlantılar Connections	Ld	Ht		D	Da

**2522-3/8"**

3/8"- ARSBEK 6311-A1	58,8	1x1x630	27,5	9800	22,0	7035	18,6	5545	$\emptyset$ 22/0 19	1275	1070	380	900	496,00 €
3/8"- ARSBEK 6311-B1	78,4	1x1x630	31,5	9390	24,6	6698	20,3	5188	$\emptyset$ 22/0 19	1275	1070	380	900	579,00 €
3/8"- ARSBEK 6312-A1	117,5	1x2x630	55,6	19600	43,2	14067	37,6	11092	$\emptyset$ 28/0 22	2275	1070	380	900	868,00 €
3/8"- ARSBEK 6312-B1	166,9	1x2x630	63,3	18780	49,6	13396	40,8	10378	$\emptyset$ 28/0 22	2275	1070	380	900	1.073,00 €
3/8"- ARSBEK 6313-A1	176,3	1x3x630	83,2	29400	66,6	21100	56,4	16637	$\emptyset$ 35/0 28	3275	1070	380	900	1.248,00 €
3/8"- ARSBEK 6313-B1	235,1	1x3x630	93,5	28170	74,0	20094	61,7	15566	$\emptyset$ 35/0 28	3275	1070	380	900	1.481,00 €
3/8"- ARSBEK 6314-A1	235,1	1x4x630	108,8	39200	87,8	28134	74,7	22184	$\emptyset$ 42/0 35	4275	1070	380	900	1.628,00 €
3/8"- ARSBEK 6314-B1	313,4	1x4x630	127,0	37560	98,9	26793	81,7	20756	$\emptyset$ 42/0 35	4275	1070	380	900	1.936,00 €
3/8"- ARSBEK 6322-A1	235,1	2x2x630	109,0	39200	86,6	28134	75,1	22184	$\emptyset$ 2x35/0 2x28	2275	2030	380	900	1.571,00 €
3/8"- ARSBEK 6322-B1	313,4	2x2x630	126,7	37560	99,4	26792	81,6	20756	$\emptyset$ 2x35/0 2x28	2275	2030	380	900	1.888,00 €
3/8"- ARSBEK 6323-A1	352,6	2x3x630	166,5	58800	133,3	42200	113,0	33274	$\emptyset$ 2x35/0 2x28	3275	2030	380	900	2.219,00 €
3/8"- ARSBEK 6323-B1	470,1	2x3x630	187,0	56340	148,0	40188	122,2	31132	$\emptyset$ 2x42/0 2x35	3275	2030	380	900	2.723,00 €
3/8"- ARSBEK 6324-A1	470,1	2x4x630	217,3	78400	175,7	56268	149,4	44368	$\emptyset$ 2x42/0 2x35	4275	2030	380	900	2.905,00 €
3/8"- ARSBEK 6324-B1	626,8	2x4x630	254,1	75120	197,8	53586	163,4	41512	$\emptyset$ 2x42/0 2x35	4275	2030	380	900	3.521,00 €

**2522-3/8"**

3/8"- ARSBEK 6311-A5	49,4	1x1x630	25,5	9956	20,6	7162	17,6	5685	$\emptyset$ 22/0 19	1275	1070	380	900	487,00 €
3/8"- ARSBEK 6311-B5	65,8	1x1x630	29,8	9580	23,7	6855	19,7	5355	$\emptyset$ 22/0 19	1275	1070	380	900	567,00 €
3/8"- ARSBEK 6312-A5	98,7	1x2x630	50,0	19915	40,5	14325	35,3	11370	$\emptyset$ 28/0 22	2275	1070	380	900	851,00 €
3/8"- ARSBEK 6312-B5	140,2	1x2x630	59,7	19165	47,4	13711	39,0	10710	$\emptyset$ 28/0 22	2275	1070	380	900	1.048,00 €
3/8"- ARSBEK 6313-A5	148,1	1x3x630	77,0	29870	62,0	21488	53,0	17060	$\emptyset$ 35/0 28	3275	1070	380	900	1.221,00 €
3/8"- ARSBEK 6313-B5	197,4	1x3x630	90,0	28750	70,5	20566	59,0	16065	$\emptyset$ 35/0 28	3275	1070	380	900	1.446,00 €
3/8"- ARSBEK 6314-A5	197,4	1x4x630	103,3	39820	82,2	28651	70,0	22744	$\emptyset$ 42/0 35	4275	1070	380	900	1.592,00 €
3/8"- ARSBEK 6314-B5	263,3	1x4x630	120,0	38330	93,8	27422	70,5	21425	$\emptyset$ 42/0 35	4275	1070	380	900	1.889,00 €
3/8"- ARSBEK 6322-A5	197,4	2x2x630	100,0	39825	80,5	28650	70,7	22742	$\emptyset$ 2x35/0 2x28	2275	2030	380	900	1.536,00 €
3/8"- ARSBEK 6322-B5	263,3	2x2x630	119,2	38335	94,5	27422	78,7	21422	$\emptyset$ 2x35/0 2x28	2275	2030	380	900	1.841,00 €
3/8"- ARSBEK 6323-A5	296,2	2x3x630	154,0	59740	124,2	42976	106,0	34114	$\emptyset$ 2x35/0 2x28	3275	2030	380	900	2.167,00 €
3/8"- ARSBEK 6323-B5	394,9	2x3x630	180,0	57500	141,0	41132	118,0	32136	$\emptyset$ 2x42/0 2x35	3275	2030	380	900	2.652,00 €
3/8"- ARSBEK 6324-A5	394,9	2x4x630	207,0	79648	164,5	57300	141,0	45488	$\emptyset$ 2x42/0 2x35	4275	2030	380	900	2.834,00 €
3/8"- ARSBEK 6324-B5	526,5	2x4x630	239,0	76660	187,7	54840	156,0	42848	$\emptyset$ 2x42/0 2x35	4275	2030	380	900	3.427,00 €

**AREK ENDÜSTRİYEL SERİ HAVA SOĞUTMALI KONDANSERLER**  
AREK SERIES INDUSTRIAL AIR COOLED CONDENSER

Lamel Aralığı Fin Spacing	MODEL MODEL	Yüzey Surface	Fan Sayısı Number of Fan	880 rpm Δ 50 Hz-3/400 V		660 rpm Y 50 Hz-3/400 V		330 rpm Y 50 Hz-3/400 V		Bağlantılar Connections	Boyutlar Dimension			Fiyat Price (Kdv 7035)	
				Kapasite Capacity	Hava Debisi Air Flow	Kapasite Capacity	Hava Debisi Air Flow	Kapasite Capacity	Hava Debisi Air Flow		Giriş (in) Çıkış (Out)	Ld	Ht		D
		m <sup>2</sup>	n	kwatt	m <sup>3</sup> /h	kwatt	m <sup>3</sup> /h	kwatt	m <sup>3</sup> /h	mm	mm	mm	mm	€	
2,1 mm Hatve / Fin Spacing	3/8"- ARSBEK 8011-A1	89,1	1x1x800	52,4	21284	44,0	16138	25,4	7350	Ø 28/Ø 22	1475	1320	500	1100	734,00 €
	3/8"- ARSBEK 8011-B1	103,9	1x1x800	57,0	22149	48,2	16972	28,0	7815	Ø 35/Ø 28	1675	1320	500	1100	832,00 €
	3/8"- ARSBEK 8011-C1	118,8	1x1x800	62,6	23010	52,4	17806	30,6	8280	Ø 35/Ø 28	1875	1320	500	1100	880,00 €
	3/8"- ARSBEK 8011-D1	138,6	1x1x800	66,0	21135	54,6	15988	30,0	7275	Ø 35/Ø 28	1675	1320	500	1100	976,00 €
	3/8"- ARSBEK 8012-A1	178,1	1x2x800	105,0	42560	88,4	32275	51,0	14700	Ø 42/Ø 35	2675	1320	500	1100	1.331,00 €
	3/8"- ARSBEK 8012-B1	207,8	1x2x800	114,5	44280	96,8	33948	55,8	15630	Ø 42/Ø 35	3075	1320	500	1100	1.484,00 €
	3/8"- ARSBEK 8012-C1	237,5	1x2x800	120,0	40120	99,7	30064	55,0	13560	Ø 42/Ø 35	2675	1320	500	1100	1.569,00 €
	3/8"- ARSBEK 8012-D1	277,1	1x2x800	132,7	42200	108,3	32000	60,0	14550	Ø 42/Ø 35	3075	1320	500	1100	1.759,00 €
	3/8"- ARSBEK 8013-A1	267,2	1x3x800	158,0	63840	132,8	48444	77,4	22050	Ø 54/Ø 42	3875	1320	500	1100	1.913,00 €
	3/8"- ARSBEK 8013-B1	311,8	1x3x800	172,0	66420	145,4	50922	84,0	23450	Ø 54/Ø 42	4475	1320	500	1100	2.141,00 €
	3/8"- ARSBEK 8013-C1	356,3	1x3x800	182,0	60180	149,0	45000	82,0	20340	Ø 54/Ø 42	3875	1320	500	1100	2.265,00 €
	3/8"- ARSBEK 8013-D1	415,7	1x3x800	200,0	63300	164,0	48000	89,0	21830	Ø 54/Ø 42	4475	1320	500	1100	2.549,00 €
	3/8"- ARSBEK 8022-A1	326,6	2x2x800	200,0	82880	168,0	57400	96,5	28300	Ø 2x42/Ø 2x35	2675	2330	500	1100	2.247,00 €
	3/8"- ARSBEK 8022-B1	381,0	2x2x800	218,5	86720	184,0	61600	106,6	30234	Ø 2x42/Ø 2x35	3975	2330	500	1100	2.517,00 €
	3/8"- ARSBEK 8022-C1	435,5	2x2x800	229,0	77560	189,0	52600	104,0	25980	Ø 2x42/Ø 2x35	2675	2330	500	1100	2.683,00 €
	3/8"- ARSBEK 8022-D1	508,1	2x2x800	247,0	82200	205,0	57000	114,0	27994	Ø 2x42/Ø 2x35	3975	2330	500	1100	3.022,00 €
	3/8"- ARSBEK 8023-A1	489,9	2x3x800	300,0	124320	252,0	86100	147,0	42450	Ø 2x54/Ø 2x42	3875	2330	500	1100	3.237,00 €
	3/8"- ARSBEK 8023-B1	571,6	2x3x800	328,5	131100	277,0	92400	160,0	45350	Ø 2x54/Ø 2x42	4475	2330	500	1100	3.640,00 €
	3/8"- ARSBEK 8023-C1	653,2	2x3x800	346,0	116340	282,0	78900	155,0	38924	Ø 2x54/Ø 2x42	3875	2330	500	1100	3.881,00 €
	3/8"- ARSBEK 8023-D1	762,1	2x3x800	380,0	123340	313,0	85500	173,0	41990	Ø 2x54/Ø 2x42	4475	2330	500	1100	4.388,00 €

**AREK ENDÜSTRİYEL SERİ HAVA SOĞUTMALI KONDANSERLER**  
AREK SERIES INDUSTRIAL AIR COOLED CONDENSERS

Lamel Aralığı Fin Spacing	MODEL MODEL	Yüzey Surface	Fan Sayısı Number of Fan	1210 rpm 50 Hz-1/230 V		900 rpm A 50 Hz-3/400 V		640 rpm Y 50 Hz-3/400 V		Bağlantılar Connections			Boyutlar Dimension			Fiyat Price (Ral/7035)
				Kapasite Capacity	Hava Debisi Air Flow	Kapasite Capacity	Hava Debisi Air Flow	Kapasite Capacity	Hava Debisi Air Flow	Giriş (in) Çıkış (Out)	Ld	Ht	D	Da		
															kwatt	
<b>3228-3/8"</b>																
3/8"- AREK 5012-A1		98,8	1x2x500	43,9	15390	35,1	11016	27,6	7850	Ø 28/Ø 22	1775	970	340	900	627,00 €	
3/8"- AREK 5012-B1		131,7	1x2x500	49,6	14600	39,1	10432	29,8	7310	Ø 28/Ø 22	1775	970	340	900	729,00 €	
3/8"- AREK 5013-A1		148,2	1x3x500	66,2	23085	53,2	16524	41,7	11750	Ø 35/Ø 28	2525	970	340	900	894,00 €	
3/8"- AREK 5013-B1		197,6	1x3x500	75,0	21900	58,0	15648	44,7	10960	Ø 35/Ø 28	2525	970	340	900	1.045,00 €	
3/8"- AREK 5014-A1		197,6	1x4x500	87,6	30780	70,0	22032	54,9	15715	Ø 42/Ø 35	3275	970	340	900	1.161,00 €	
3/8"- AREK 5014-B1		263,5	1x4x500	100,0	29200	78,5	20864	59,6	14615	Ø 42/Ø 35	3275	970	340	900	1.360,00 €	
3/8"- AREK 5022-A1		197,6	2x2x500	87,8	30780	70,0	22032	54,9	15715	Ø 42/Ø 35	1775	1830	340	900	1.123,00 €	
3/8"- AREK 5022-B1		263,5	2x2x500	99,4	16800	78,3	20864	59,5	14615	Ø 42/Ø 35	1775	1830	340	900	1.328,00 €	
3/8"- AREK 5023-A1		296,4	2x3x500	132,6	43800	106,4	33048	83,7	23575	Ø 42/Ø 35	2525	1.830	340	900	1.559,00 €	
3/8"- AREK 5023-B1		395,2	2x3x500	150,0	61558	116,0	31296	88,2	21925	Ø 54/Ø 42	2525	1.830	340	900	1.889,00 €	
3/8"- AREK 5024-A1		395,2	2x4x500	175,2	61558	140,0	44064	109,8	31430	Ø 54/Ø 42	3275	1.830	340	900	2.023,00 €	
3/8"- AREK 5024-B1		527,0	2x4x500	200,0	58400	157,0	41728	119,2	29230	Ø 54/Ø 42	3275	1.830	340	900	2.421,00 €	
<b>3228-3/8"</b>																
<b>3228-3/8"</b>																
3/8"- AREK 5012-A5		83,0	1x2x500	40,5	15633	32,7	11198	26,1	8040	Ø 28/Ø 22	1775	970	340	900	609,00 €	
3/8"- AREK 5012-B5		110,7	1x2x500	47,0	14904	37,3	10658	28,8	7520	Ø 28/Ø 22	1775	970	340	900	705,00 €	
3/8"- AREK 5013-A5		124,5	1x3x500	61,3	23450	49,2	16800	39,5	12060	Ø 35/Ø 28	2525	970	340	900	867,00 €	
3/8"- AREK 5013-B5		166,0	1x3x500	69,8	22350	55,9	15985	43,3	11280	Ø 35/Ø 28	2525	970	340	900	1.008,00 €	
3/8"- AREK 5014-A5		166,0	1x4x500	82,0	31265	65,1	22397	51,8	16075	Ø 42/Ø 35	3275	970	340	900	1.124,00 €	
3/8"- AREK 5014-B5		221,3	1x4x500	94,1	29810	74,8	21315	57,7	15040	Ø 42/Ø 35	3275	970	340	900	1.311,00 €	
3/8"- AREK 5022-A5		166,0	2x2x500	80,6	31265	65,1	22395	51,7	16080	Ø 42/Ø 35	1775	1830	340	900	1.087,00 €	
3/8"- AREK 5022-B5		221,3	2x2x500	93,8	29810	74,6	21315	57,7	15040	Ø 42/Ø 35	1775	1830	340	900	1.280,00 €	
3/8"- AREK 5023-A5		249,0	2x3x500	139,6	46900	98,8	33595	79,2	24115	Ø 42/Ø 35	2525	1.830	340	900	1.504,00 €	
3/8"- AREK 5023-B5		332,0	2x3x500	139,6	44700	110,2	31975	84,8	22550	Ø 54/Ø 42	2525	1.830	340	900	1.816,00 €	
3/8"- AREK 5024-A5		332,0	2x4x500	164,0	62530	130,3	44795	103,6	32150	Ø 54/Ø 42	3275	1.830	340	900	1.951,00 €	
3/8"- AREK 5024-B5		442,7	2x4x500	188,4	59620	149,5	42634	115,3	30075	Ø 54/Ø 42	3275	1.830	340	900	2.325,00 €	

**AREK ENDÜSTRİYEL SERİ HAVA SOĞUTMALI KONDANSERLER**  
AREK SERIES INDUSTRIAL AIR COOLED CONDENSERS

Lamel Aralığı Fin Spacing	MODEL MODEL	Yüzey Surface	Fan Sayısı Number of Fan	900 rpm			650 rpm Δ			480 rpm Y			Boyutlar Dimension			Fiyat Price (Ral: 7035)	
				50 Hz-1/230 V			50 Hz-3/400 V			50 Hz-3/400 V			Ld	Ht	D		Da
				Kapasite Capacity	Hava Debisi Air Flow	1 Fan için Akım ve Güç değerleri Current and Power rate for 1 Fan I : 3,50 Amp P : 0,78 kW	Kapasite Capacity	Hava Debisi Air Flow	1 Fan için Akım ve Güç değerleri Current and Power rate for 1 Fan I : 0,80 Amp P : 0,33 kW	Kapasite Capacity	Hava Debisi Air Flow	1 Fan için Akım ve Güç değerleri Current and Power rate for 1 Fan I : 0,38 Amp P : 0,19 kW					
m <sup>2</sup>	n	m <sup>3</sup> /h	kwatt	m <sup>3</sup> /h	kwatt	m <sup>3</sup> /h	kwatt	m <sup>3</sup> /h	kwatt	m <sup>3</sup> /h	mm	mm	mm	mm	€		
<b>3228-3/8"</b>																	
3/8"- AREK 6312-A1		152,0	1x2x630	52,5	19600	42,5	14066	36,1	11092	Ø 35/Ø 28	2275	1070	400	900	851,00 €		
3/8"- AREK 6312-B1		202,7	1x2x630	60,1	18780	47,7	13396	39,5	10378	Ø 35/Ø 28	2275	1070	400	900	993,00 €		
3/8"- AREK 6313-A1		228,0	1x3x630	77,2	29400	63,5	21100	54,4	16637	Ø 42/Ø 35	3275	1070	400	900	1.213,00 €		
3/8"- AREK 6313-B1		304,0	1x3x630	83,7	28170	68,5	20094	57,7	15566	Ø 42/Ø 35	3275	1070	400	900	1.424,00 €		
3/8"- AREK 6314-A1		304,0	1x4x630	95,1	39200	80,2	28134	69,8	22184	Ø 54/Ø 42	4274	1070	400	900	1.651,00 €		
3/8"- AREK 6314-B1		405,4	1x4x630	97,7	37560	83,0	26793	71,6	20756	Ø 54/Ø 42	4275	1070	400	900	1.955,00 €		
3/8"- AREK 6322-A1		304,0	2x2x630	94,0	39200	79,5	28134	69,3	22184	Ø 2x35/Ø 2x28	2275	2030	400	900	1.572,00 €		
3/8"- AREK 6322-B1		405,4	2x2x630	96,0	37560	81,9	26792	70,9	20756	Ø 2x35/Ø 2x28	2275	2030	400	900	1.883,00 €		
3/8"- AREK 6323-A1		456,0	2x3x630	154,3	58800	126,9	42200	108,7	33274	Ø 2x42/Ø 2x35	3275	2030	400	900	2.258,00 €		
3/8"- AREK 6323-B1		608,0	2x3x630	167,4	56340	136,9	40188	115,4	31132	Ø 2x42/Ø 2x35	3275	2030	400	900	2.717,00 €		
3/8"- AREK 6324-A1		608,0	2x4x630	190,2	78400	160,4	56268	139,6	44368	Ø 2x42/Ø 2x35	4274	2030	400	900	2.906,00 €		
3/8"- AREK 6324-B1		810,7	2x4x630	195,2	75120	165,9	53586	143,2	41512	Ø 2x42/Ø 2x35	4275	2030	400	900	3.513,00 €		
3/8"- AREK 6325-A1		760,0	2x5x630	214,8	97800	186,2	70000	165,4	55500	Ø 2x54/Ø 2x42	5275	2030	400	900	3.617,00 €		
3/8"- AREK 6325-B1		1013,4	2x5x630	257,8	93800	220,0	68900	185,2	51900	Ø 2x54/Ø 2x42	5275	2030	400	900	4.378,00 €		
3/8"- AREK 6326-A1		912,1	2x6x630	292,0	117300	245,5	84200	212,2	66000	Ø 2x54/Ø 2x42	6275	2030	400	900	4.265,00 €		
3/8"- AREK 6326-B1		1216,1	2x6x630	303,5	112900	255,0	80000	218,8	61900	Ø 2x54/Ø 2x42	6275	2030	400	900	5.174,00 €		
<b>3228-3/8"</b>																	
3/8"- AREK 6312-A5		127,7	1x2x630	49,4	19660	40,1	14117	34,2	11147	Ø 35/Ø 28	2275	1070	400	900	823,00 €		
3/8"- AREK 6312-B5		170,3	1x2x630	57,3	18857	45,7	13457	37,9	10444	Ø 35/Ø 28	2275	1070	400	900	956,00 €		
3/8"- AREK 6313-A5		191,5	1x3x630	73,2	29490	60,2	21177	51,7	16721	Ø 42/Ø 35	3275	1070	400	900	1.171,00 €		
3/8"- AREK 6313-B5		255,4	1x3x630	80,7	28286	65,9	20187	55,8	15666	Ø 42/Ø 35	3275	1070	400	900	1.368,00 €		
3/8"- AREK 6314-A5		255,4	1x4x630	94,5	42640	76,6	28236	66,7	22295	Ø 54/Ø 42	4274	1070	400	900	1.595,00 €		
3/8"- AREK 6314-B5		340,5	1x4x630	94,9	37714	80,5	26916	69,5	20888	Ø 54/Ø 42	4275	1070	400	900	1.880,00 €		
3/8"- AREK 6322-A5		255,4	2x2x630	90,1	39320	76,0	28234	66,3	22294	Ø 2x35/Ø 2x28	2275	2030	400	900	1.517,00 €		
3/8"- AREK 6322-B5		340,5	2x2x630	93,5	37714	79,6	26914	68,9	20888	Ø 2x35/Ø 2x28	2275	2030	400	900	1.808,00 €		
3/8"- AREK 6323-A5		383,1	2x3x630	146,3	58980	120,3	42354	103,3	33442	Ø 2x42/Ø 2x35	3275	2030	400	900	2.175,00 €		
3/8"- AREK 6323-B5		510,8	2x3x630	161,3	56570	131,9	40374	111,4	31332	Ø 2x42/Ø 2x35	3275	2030	400	900	2.605,00 €		
3/8"- AREK 6324-A5		510,8	2x4x630	188,5	85280	153,2	56472	133,4	44590	Ø 2x42/Ø 2x35	4274	2030	400	900	2.795,00 €		
3/8"- AREK 6324-B5		681,0	2x4x630	191,0	75428	161,1	53832	139,0	41776	Ø 2x42/Ø 2x35	4275	2030	400	900	3.364,00 €		
3/8"- AREK 6325-A5		638,4	2x5x630	204,7	98300	177,1	70590	156,9	55738	Ø 2x54/Ø 2x42	5275	2030	400	900	3.477,00 €		
3/8"- AREK 6325-B5		851,3	2x5x630	246,8	94280	207,2	67290	177,9	52222	Ø 2x54/Ø 2x42	5275	2030	400	900	4.192,00 €		
3/8"- AREK 6326-A5		766,1	2x6x630	274,0	117960	230,5	84708	200,5	66886	Ø 2x54/Ø 2x42	6275	2030	400	900	4.097,00 €		
3/8"- AREK 6326-B5		1021,5	2x6x630	291,0	113136	245,2	80748	211,2	62666	Ø 2x54/Ø 2x42	6275	2030	400	900	4.951,00 €		

**AREK ENDÜSTRİYEL SERİ HAVA SOĞUTMALI KONDANSERLER**  
AREK SERIES INDUSTRIAL AIR COOLED CONDENSER

Lamel Aralığı Fin Spacing	MODEL MODEL	Yüzey Surface	Fan Sayısı Number of Fan	880 rpm $\Delta$ 50 Hz-3/400 V		660 rpm $\Upsilon$ 50 Hz-3/400 V		330 rpm $Y$ 50 Hz-3/400 V		Boyutlar Dimension			Fiyat Price (Ral 7035)		
				Kapasite Capacity	Hava Debisi Air Flow	Kapasite Capacity	Hava Debisi Air Flow	Kapasite Capacity	Hava Debisi Air Flow	Bağlantılar Connections	Ld	Ht		D	Da
<b>3228-3/8"</b>															
2,1 mm Hatve / Fin Spacing	3/8"-AREK 8011-A1	115,5	1x1x800	42,5	21900	36,5	16750	22,7	7900	Ø 28/Ø 22	1475	1320	500	1100	703,00 €
	3/8"-AREK 8011-B1	134,8	1x1x800	52,7	22650	45,1	17475	27,3	8300	Ø 35/Ø 28	1675	1320	500	1100	796,00 €
	3/8"-AREK 8011-C1	154,0	1x1x800	58,7	21600	47,6	15600	27,1	7255	Ø 35/Ø 28	1475	1320	500	1100	838,00 €
	3/8"-AREK 8012-A1	179,7	1x1x800	63,0	21650	52,8	16515	30,1	7750	Ø 35/Ø 28	1675	1320	500	1100	925,00 €
	3/8"-AREK 8012-B1	231,1	1x2x800	110,2	41970	95,2	31717	54,6	14400	Ø 42/Ø 35	2675	1320	500	1100	1.265,00 €
	3/8"-AREK 8012-C1	269,6	1x2x800	122,0	43808	103,5	33459	59,5	15350	Ø 42/Ø 35	3075	1320	500	1100	1.408,00 €
	3/8"-AREK 8013-A1	308,1	1x2x800	128,3	39415	105,3	29428	57,0	13250	Ø 42/Ø 35	2675	1320	500	1100	1.480,00 €
	3/8"-AREK 8013-B1	359,4	1x2x800	140,3	41660	115,1	31430	62,0	14250	Ø 54/Ø 42	3075	1320	500	1100	1.681,00 €
	3/8"-AREK 8013-C1	346,6	1x3x800	170,0	62960	142,7	47578	82,1	21600	Ø 54/Ø 42	3875	1320	500	1100	1.901,00 €
	3/8"-AREK 8014-A1	404,3	1x3x800	184,2	65714	156,0	50189	89,0	23030	Ø 54/Ø 42	4475	1320	500	1100	2.127,00 €
	3/8"-AREK 8014-B1	539,1	1x3x800	208,0	62490	173,0	47146	93,0	21380	Ø 54/Ø 42	4475	1320	500	1100	2.529,00 €
	3/8"-AREK 8014-C1	462,1	1x4x800	227,0	83945	191,6	63436	109,2	28810	Ø 66/Ø 54	5075	1320	500	1100	2.248,00 €
	3/8"-AREK 8014-D1	539,1	1x4x800	247,2	87618	208,7	66918	118,4	30715	Ø 66/Ø 54	5875	1320	500	1100	2.817,00 €
	3/8"-AREK 8014-E1	616,1	1x4x800	257,0	78835	209,2	58819	112,6	26500	Ø 66/Ø 54	5075	1320	500	1100	2.979,00 €
	3/8"-AREK 8014-F1	718,8	1x4x800	281,4	83320	230,4	62862	123,2	28500	Ø 66/Ø 54	5875	1320	500	1100	3.354,00 €
	3/8"-AREK 8022-A1	413,5	2x2x800	212,3	80840	177,6	60638	102,0	27370	Ø 2x42/Ø 2x35	2675	2330	500	1100	2.188,00 €
	3/8"-AREK 8022-B1	482,4	2x2x800	231,4	85040	192,1	64452	111,6	29350	Ø 2x42/Ø 2x35	3075	2330	500	1100	2.450,00 €
	3/8"-AREK 8022-C1	551,3	2x2x800	239,6	75170	194,8	55708	106,5	25050	Ø 2x42/Ø 2x35	2675	2330	500	1100	2.606,00 €
	3/8"-AREK 8023-A1	620,2	2x3x800	318,0	80150	215,9	60018	116,7	27070	Ø 2x54/Ø 2x42	3075	2330	500	1100	2.935,00 €
	3/8"-AREK 8023-B1	723,6	2x3x800	345,8	127560	292,8	96678	167,7	44030	Ø 2x54/Ø 2x42	3875	2330	500	1100	3.138,00 €
	3/8"-AREK 8023-C1	826,9	2x3x800	363,2	112760	294,2	83568	159,7	37580	Ø 2x54/Ø 2x42	3875	2330	500	1100	3.758,00 €
	3/8"-AREK 8024-A1	964,8	2x3x800	398,8	120330	325,5	90126	174,5	40600	Ø 2x54/Ø 2x42	4475	2330	500	1100	4.249,00 €
	3/8"-AREK 8024-B1	826,9	2x4x800	427,6	161720	355,7	121282	204,4	54750	Ø 2x66/Ø 2x54	5075	2330	500	1100	4.062,00 €
	3/8"-AREK 8024-C1	964,8	2x4x800	470,4	170080	393,9	128306	223,3	58705	Ø 2x66/Ø 2x54	5875	2330	500	1100	4.691,00 €
	3/8"-AREK 8024-D1	1102,6	2x4x800	480,0	150350	390,0	111422	213,6	51000	Ø 2x66/Ø 2x54	5075	2330	500	1100	4.999,00 €
	3/8"-AREK 8025-A1	1286,3	2x4x800	529,1	160310	432,2	120034	234,0	54135	Ø 2x66/Ø 2x54	5875	2330	500	1100	5.653,00 €
	3/8"-AREK 8025-B1	1033,7	2x5x800	529,0	202150	441,0	151606	256,2	68440	Ø 2x66/Ø 2x54	6275	2330	500	1100	5.074,00 €
	3/8"-AREK 8025-C1	1205,9	2x5x800	582,1	212600	488,0	161136	281,6	73380	Ø 2x66/Ø 2x54	7275	2330	500	1100	5.725,00 €
	3/8"-AREK 8025-D1	1378,2	2x5x800	600,0	187940	490,5	139202	265,4	62630	Ø 2x80/Ø 2x66	6275	2330	500	1100	6.104,00 €
	3/8"-AREK 8026-A1	1607,9	2x5x800	653,3	200390	538,3	150018	291,7	67670	Ø 2x80/Ø 2x66	7275	2330	500	1100	7.107,00 €
	3/8"-AREK 8026-B1	1240,4	2x6x800	620,0	242600	533,5	181926	309,1	82130	Ø 2x80/Ø 2x66	7475	2330	500	1100	6.164,00 €
	3/8"-AREK 8026-C1	1447,1	2x6x800	691,0	255120	585,0	173362	338,0	88060	Ø 2x80/Ø 2x66	8675	2330	500	1100	7.294,00 €
	3/8"-AREK 8026-D1	1653,9	2x6x800	709,0	225520	583,6	167136	319,8	75150	Ø 2x80/Ø 2x66	7475	2330	500	1100	7.795,00 €
	3/8"-AREK 8026-E1	1929,5	2x6x800	782,4	240470	637,2	18800	349,4	81200	Ø 2x80/Ø 2x66	8675	2330	500	1100	8.841,00 €

**AREK ENDÜSTRİYEL SERİ HAVA SOĞUTMALI KONDANSERLER**  
AREK SERIES INDUSTRIYAL AIR COOLED CONDENSERS

MODEL MODEL	Yüzey Surface	Fan Sayısı Number of Fan	880 rpm $\Delta$		660 rpm $\Upsilon$		330 rpm $\Upsilon$		Bağlantılar Connections			Boyutlar Dimension			Fiyat Price (Ral 7035)	
			50 Hz-3/400 V		50 Hz-3/400 V		50 Hz-3/400 V		Giriş (in) Çıkış (Out)			Ld	Ht	D		Da
			Kapasite Capacity	Hava Debisi Air Flow	Kapasite Capacity	Hava Debisi Air Flow	Kapasite Capacity	Hava Debisi Air Flow	mm	mm	mm	mm	mm	mm		
<b>3228-3/8"</b>																
3/8"- AREK 8011-A5	97,0	1x1x800	42,6	22000	36,7	16850	23,1	8100	$\emptyset$ 28/ $\emptyset$ 22	1475	1320	500	1100	682,00 €		
3/8"- AREK 8011-B5	113,2	1x1x800	47,6	22650	41,0	17475	25,3	8300	$\emptyset$ 35/ $\emptyset$ 28	1675	1320	500	1100	772,00 €		
3/8"- AREK 8011-C5	129,4	1x1x800	54,0	21900	44,4	15900	26,1	7455	$\emptyset$ 35/ $\emptyset$ 28	1475	1320	500	1100	810,00 €		
3/8"- AREK 8011-D5	151,0	1x1x800	58,4	21950	49,3	16815	29,2	8050	$\emptyset$ 35/ $\emptyset$ 28	1675	1320	500	1100	892,00 €		
3/8"- AREK 8012-A5	194,1	1x2x800	110,2	41970	95,2	31717	54,6	14400	$\emptyset$ 42/ $\emptyset$ 35	2675	1320	500	1100	1.223,00 €		
3/8"- AREK 8012-B5	226,4	1x2x800	122,0	43808	103,5	33459	59,5	15350	$\emptyset$ 42/ $\emptyset$ 35	3075	1320	500	1100	1.358,00 €		
3/8"- AREK 8012-C5	258,8	1x2x800	128,3	39415	105,3	29428	57,0	13250	$\emptyset$ 42/ $\emptyset$ 35	2675	1320	500	1100	1.424,00 €		
3/8"- AREK 8012-D5	301,9	1x2x800	140,3	41660	115,1	31430	62,0	14250	$\emptyset$ 54/ $\emptyset$ 42	3075	1320	500	1100	1.615,00 €		
3/8"- AREK 8013-A5	291,1	1x3x800	170,0	62960	142,7	47578	82,1	21600	$\emptyset$ 54/ $\emptyset$ 42	3875	1320	500	1100	1.838,00 €		
3/8"- AREK 8013-B5	339,6	1x3x800	184,2	65714	156,0	50189	89,0	23030	$\emptyset$ 54/ $\emptyset$ 42	4475	1320	500	1100	2.053,00 €		
3/8"- AREK 8013-C5	388,2	1x3x800	207,0	59125	158,6	44145	85,3	19980	$\emptyset$ 54/ $\emptyset$ 42	3875	1320	500	1100	2.163,00 €		
3/8"- AREK 8013-D5	452,9	1x3x800	208,0	62490	173,0	47146	93,0	21380	$\emptyset$ 54/ $\emptyset$ 42	4475	1320	500	1100	2.431,00 €		
3/8"- AREK 8014-A5	358,2	1x4x800	227,0	83945	191,6	63436	109,2	28810	$\emptyset$ 66/ $\emptyset$ 54	5075	1320	500	1100	2.373,00 €		
3/8"- AREK 8014-B5	422,9	1x4x800	247,2	87618	208,7	66918	118,4	30715	$\emptyset$ 66/ $\emptyset$ 54	5875	1320	500	1100	2.718,00 €		
3/8"- AREK 8014-C5	517,6	1x4x800	257,0	78835	209,2	58819	112,6	26500	$\emptyset$ 66/ $\emptyset$ 54	5075	1320	500	1100	2.866,00 €		
3/8"- AREK 8014-D5	603,8	1x4x800	281,4	83320	230,4	62862	123,2	28500	$\emptyset$ 66/ $\emptyset$ 54	5875	1320	500	1100	3.222,00 €		
3/8"- AREK 8022-A5	347,3	2x2x800	212,3	80840	177,6	60638	102,0	27370	$\emptyset$ 2x42/ $\emptyset$ 2x35	2675	2330	500	1100	2.112,00 €		
3/8"- AREK 8022-B5	405,2	2x2x800	231,4	85040	192,1	64452	111,6	29350	$\emptyset$ 2x42/ $\emptyset$ 2x35	3075	2330	500	1100	2.361,00 €		
3/8"- AREK 8022-C5	463,1	2x2x800	239,6	75170	194,8	55708	106,5	25050	$\emptyset$ 2x42/ $\emptyset$ 2x35	2675	2330	500	1100	2.505,00 €		
3/8"- AREK 8022-D5	540,3	2x2x800	264,0	80150	215,9	60018	116,7	27070	$\emptyset$ 2x42/ $\emptyset$ 2x35	3075	2330	500	1100	2.817,00 €		
3/8"- AREK 8023-A5	521,0	2x3x800	318,0	121290	266,4	90960	153,8	41060	$\emptyset$ 2x54/ $\emptyset$ 2x42	3875	2330	500	1100	3.024,00 €		
3/8"- AREK 8023-B5	607,8	2x3x800	345,8	127560	292,8	96678	167,7	44030	$\emptyset$ 2x54/ $\emptyset$ 2x42	4475	2330	500	1100	3.397,00 €		
3/8"- AREK 8023-C5	694,6	2x3x800	363,2	112760	294,2	83568	159,7	37580	$\emptyset$ 2x54/ $\emptyset$ 2x42	3875	2330	500	1100	3.606,00 €		
3/8"- AREK 8023-D5	810,4	2x3x800	398,8	120330	325,5	90126	174,5	40600	$\emptyset$ 2x54/ $\emptyset$ 2x42	4475	2330	500	1100	4.072,00 €		
3/8"- AREK 8024-A5	694,6	2x4x800	427,6	161720	355,7	121282	204,4	54750	$\emptyset$ 2x54/ $\emptyset$ 2x42	5075	2330	500	1100	3.911,00 €		
3/8"- AREK 8024-B5	810,4	2x4x800	470,4	170080	393,9	128306	223,3	58705	$\emptyset$ 2x66/ $\emptyset$ 2x54	5875	2330	500	1100	4.515,00 €		
3/8"- AREK 8024-C5	926,2	2x4x800	480,0	150350	390,0	111422	213,6	51000	$\emptyset$ 2x66/ $\emptyset$ 2x54	5075	2330	500	1100	4.796,00 €		
3/8"- AREK 8024-D5	1080,5	2x4x800	529,1	160310	432,2	120034	234,0	54135	$\emptyset$ 2x66/ $\emptyset$ 2x54	5875	2330	500	1100	5.417,00 €		
3/8"- AREK 8025-A5	868,3	2x5x800	529,0	202150	441,0	151606	256,2	68440	$\emptyset$ 2x66/ $\emptyset$ 2x54	6275	2330	500	1100	4.884,00 €		
3/8"- AREK 8025-B5	1013,0	2x5x800	582,1	212600	488,0	161136	281,6	73380	$\emptyset$ 2x66/ $\emptyset$ 2x54	7275	2330	500	1100	5.504,00 €		
3/8"- AREK 8025-C5	1157,7	2x5x800	600,0	187940	490,5	139202	265,4	62630	$\emptyset$ 2x66/ $\emptyset$ 2x54	6275	2330	500	1100	5.851,00 €		
3/8"- AREK 8025-D5	1350,7	2x5x800	653,3	200390	538,3	150018	291,7	67670	$\emptyset$ 2x80/ $\emptyset$ 2x66	7275	2330	500	1100	6.812,00 €		
3/8"- AREK 8026-A5	1041,9	2x6x800	620,0	242600	533,5	181926	309,1	82130	$\emptyset$ 2x80/ $\emptyset$ 2x66	7475	2330	500	1100	5.936,00 €		
3/8"- AREK 8026-B5	1215,6	2x6x800	691,0	255120	585,0	173362	338,0	88060	$\emptyset$ 2x80/ $\emptyset$ 2x66	8675	2330	500	1100	7.029,00 €		
3/8"- AREK 8026-C5	1389,2	2x6x800	709,0	225520	583,6	167136	319,8	75150	$\emptyset$ 2x80/ $\emptyset$ 2x66	7475	2330	500	1100	7.491,00 €		
3/8"- AREK 8026-D5	1620,8	2x6x800	782,4	240470	637,2	18800	349,4	81200	$\emptyset$ 2x80/ $\emptyset$ 2x66	8675	2330	500	1100	8.487,00 €		
<b>2,5 mm Havle / Fin Spacing</b>																



**AREK ENDÜSTRİYEL SERİ HAVA SOĞUTMALI KONDANSERLER**  
AREK SERIES INDUSTRIAL AIR COOLED CONDENSER

MODEL	Yüzey Surface	Fan Sayısı Number of Fan	880 rpm $\Delta$		660 rpm $\Upsilon$		330 rpm $\Upsilon$		Boyutlar Dimension				Fiyat Price (Ral/ 7035)
			50 Hz-3/400 V		50 Hz-3/400 V		50 Hz-3/400 V		Ld	Ht	D	Da	
			Kapasite Capacity	Hava Debisi Air Flow	Kapasite Capacity	Hava Debisi Air Flow	Kapasite Capacity	Hava Debisi Air Flow					
1/2"- AREK 5012-A1	152,0	1x2x500	43,9	15390	35,1	11016	27,6	7850	2275	1070	340	900	918,00 €
1/2"- AREK 5012-B1	202,7	1x2x500	49,6	14600	39,1	10432	29,8	7310	2275	1070	340	900	1.100,00 €
1/2"- AREK 5013-A1	228,0	1x3x500	66,2	23085	53,2	16524	41,7	11750	3275	1070	340	900	1.315,00 €
1/2"- AREK 5013-B1	304,0	1x3x500	75,0	21900	58,0	15648	44,7	10960	3275	1070	340	900	1.584,00 €
1/2"- AREK 5014-A1	304,0	1x4x500	87,6	30780	70,0	22032	54,9	15715	4274	1070	340	900	1.713,00 €
1/2"- AREK 5014-B1	405,4	1x4x500	100,0	29200	78,5	20864	59,6	14615	4275	1070	340	900	2.068,00 €
1/2"- AREK 5022-A1	304,0	2x2x500	87,8	30780	70,0	22032	54,9	15715	2275	2030	340	900	1.650,00 €
1/2"- AREK 5022-B1	405,4	2x2x500	99,4	16800	78,3	20864	59,5	14615	2275	2030	340	900	2.014,00 €
1/2"- AREK 5023-A1	456,0	2x3x500	132,6	43800	106,4	33048	83,7	23575	3275	2030	340	900	2.377,00 €
1/2"- AREK 5023-B1	608,0	2x3x500	150,0	61558	116,0	31296	88,2	21925	3275	2030	340	900	2.914,00 €
1/2"- AREK 5024-A1	608,0	2x4x500	175,2	61558	140,0	44064	109,8	31430	4274	2030	340	900	3.068,00 €
1/2"- AREK 5024-B1	810,7	2x4x500	200,0	58400	157,0	41728	119,2	29230	4275	2030	340	900	3.778,00 €
<b>3228-1/2"</b>													
1/2"- AREK 5012-A5	127,7	1x2x500	40,5	15633	32,7	11198	26,1	8040	2275	1070	340	900	891,00 €
1/2"- AREK 5012-B5	170,3	1x2x500	47,0	14904	37,3	10658	28,8	7520	2275	1070	340	900	1.064,00 €
1/2"- AREK 5013-A5	191,5	1x3x500	61,3	23450	49,2	16800	39,5	12060	3275	1070	340	900	1.275,00 €
1/2"- AREK 5013-B5	255,4	1x3x500	69,8	22350	55,9	15985	43,3	11280	3275	1070	340	900	1.530,00 €
1/2"- AREK 5014-A5	255,4	1x4x500	82,0	31265	65,1	22397	51,8	16075	4274	1070	340	900	1.659,00 €
1/2"- AREK 5014-B5	340,5	1x4x500	94,1	29810	74,8	21315	57,7	15040	4275	1070	340	900	1.996,00 €
1/2"- AREK 5022-A5	255,4	2x2x500	80,6	31265	65,1	22395	51,7	16080	2275	2030	340	900	1.596,00 €
1/2"- AREK 5022-B5	340,5	2x2x500	93,8	29810	74,8	21315	57,7	15040	2275	2030	340	900	1.942,00 €
1/2"- AREK 5023-A5	383,1	2x3x500	139,6	46900	98,8	33595	79,2	24115	3275	2030	340	900	2.294,00 €
1/2"- AREK 5023-B5	510,8	2x3x500	139,6	44700	110,2	31975	84,8	22550	3275	2030	340	900	2.806,00 €
1/2"- AREK 5024-A5	510,8	2x4x500	164,0	62530	130,3	44795	103,6	32150	4274	2030	340	900	2.960,00 €
1/2"- AREK 5024-B5	681,0	2x4x500	188,4	59620	149,5	42634	115,3	30075	4275	2030	340	900	3.634,00 €
<b>2,1 mm Hava / Fin Spacing</b>													
<b>3228-1/2"</b>													
1/2"- AREK 5012-A5	127,7	1x2x500	40,5	15633	32,7	11198	26,1	8040	2275	1070	340	900	891,00 €
1/2"- AREK 5012-B5	170,3	1x2x500	47,0	14904	37,3	10658	28,8	7520	2275	1070	340	900	1.064,00 €
1/2"- AREK 5013-A5	191,5	1x3x500	61,3	23450	49,2	16800	39,5	12060	3275	1070	340	900	1.275,00 €
1/2"- AREK 5013-B5	255,4	1x3x500	69,8	22350	55,9	15985	43,3	11280	3275	1070	340	900	1.530,00 €
1/2"- AREK 5014-A5	255,4	1x4x500	82,0	31265	65,1	22397	51,8	16075	4274	1070	340	900	1.659,00 €
1/2"- AREK 5014-B5	340,5	1x4x500	94,1	29810	74,8	21315	57,7	15040	4275	1070	340	900	1.996,00 €
1/2"- AREK 5022-A5	255,4	2x2x500	80,6	31265	65,1	22395	51,7	16080	2275	2030	340	900	1.596,00 €
1/2"- AREK 5022-B5	340,5	2x2x500	93,8	29810	74,8	21315	57,7	15040	2275	2030	340	900	1.942,00 €
1/2"- AREK 5023-A5	383,1	2x3x500	139,6	46900	98,8	33595	79,2	24115	3275	2030	340	900	2.294,00 €
1/2"- AREK 5023-B5	510,8	2x3x500	139,6	44700	110,2	31975	84,8	22550	3275	2030	340	900	2.806,00 €
1/2"- AREK 5024-A5	510,8	2x4x500	164,0	62530	130,3	44795	103,6	32150	4274	2030	340	900	2.960,00 €
1/2"- AREK 5024-B5	681,0	2x4x500	188,4	59620	149,5	42634	115,3	30075	4275	2030	340	900	3.634,00 €
<b>2,5 mm Hava / Fin Spacing</b>													
<b>3228-1/2"</b>													
1/2"- AREK 5012-A5	127,7	1x2x500	40,5	15633	32,7	11198	26,1	8040	2275	1070	340	900	891,00 €
1/2"- AREK 5012-B5	170,3	1x2x500	47,0	14904	37,3	10658	28,8	7520	2275	1070	340	900	1.064,00 €
1/2"- AREK 5013-A5	191,5	1x3x500	61,3	23450	49,2	16800	39,5	12060	3275	1070	340	900	1.275,00 €
1/2"- AREK 5013-B5	255,4	1x3x500	69,8	22350	55,9	15985	43,3	11280	3275	1070	340	900	1.530,00 €
1/2"- AREK 5014-A5	255,4	1x4x500	82,0	31265	65,1	22397	51,8	16075	4274	1070	340	900	1.659,00 €
1/2"- AREK 5014-B5	340,5	1x4x500	94,1	29810	74,8	21315	57,7	15040	4275	1070	340	900	1.996,00 €
1/2"- AREK 5022-A5	255,4	2x2x500	80,6	31265	65,1	22395	51,7	16080	2275	2030	340	900	1.596,00 €
1/2"- AREK 5022-B5	340,5	2x2x500	93,8	29810	74,8	21315	57,7	15040	2275	2030	340	900	1.942,00 €
1/2"- AREK 5023-A5	383,1	2x3x500	139,6	46900	98,8	33595	79,2	24115	3275	2030	340	900	2.294,00 €
1/2"- AREK 5023-B5	510,8	2x3x500	139,6	44700	110,2	31975	84,8	22550	3275	2030	340	900	2.806,00 €
1/2"- AREK 5024-A5	510,8	2x4x500	164,0	62530	130,3	44795	103,6	32150	4274	2030	340	900	2.960,00 €
1/2"- AREK 5024-B5	681,0	2x4x500	188,4	59620	149,5	42634	115,3	30075	4275	2030	340	900	3.634,00 €

**AREK ENDÜSTRİYEL SERİ HAVA SOĞUTMALI KONDANSERLER**  
AREK SERIES INDUSTRIAL AIR COOLED CONDENSER

Lamel Aralığı Fin Spacing	MODEL MODEL	Yüzey Surface	Fan Sayısı Number of Fan	880 rpm $\Delta$ 50 Hz-3/400 V 1 Fan için Akım ve Güç değerleri Current and Power rate for 1 Fan I : 4,0 Amp P : 2,00 kW		660 rpm $\Upsilon$ 50 Hz-3/400 V 1 Fan için Akım ve Güç değerleri Current and Power rate for 1 Fan I : 2,30 Amp P : 1,25 kW		330 rpm $\Upsilon$ 50 Hz-3/400 V 1 Fan için Akım ve Güç değerleri Current and Power rate for 1 Fan I : 0,60 Amp P : 0,20 kW		Boyutlar Dimension				Fiyat Price	
				Kapasite Capacity	Hava Debisi Air Flow	Kapasite Capacity	Hava Debisi Air Flow	Kapasite Capacity	Hava Debisi Air Flow	Bağlantılar Connections	Ld	Ht	D		Da
<b>3228-1/2"</b>															
1/2"- AREK 6312-A1	152,0	1x2x630	59,5	19390	47,1	13892	39,5	10900	$\emptyset$ 35/ $\emptyset$ 28	2275	1070	400	900	958,00 €	
1/2"- AREK 6312-B1	202,7	1x2x630	67,3	18525	52,0	13185	42,2	10158	$\emptyset$ 35/ $\emptyset$ 28	2275	1070	400	900	1.140,00 €	
1/2"- AREK 6313-A1	228,0	1x3x630	88,8	29083	70,6	20837	59,7	16355	$\emptyset$ 42/ $\emptyset$ 35	3275	1070	400	900	1.371,00 €	
1/2"- AREK 6313-B1	304,0	1x3x630	101,1	27787	78,0	19777	63,4	15235	$\emptyset$ 42/ $\emptyset$ 35	3275	1070	400	900	1.639,00 €	
1/2"- AREK 6314-A1	304,0	1x4x630	119,2	38776	95,0	27784	79,7	21800	$\emptyset$ 54/ $\emptyset$ 42	4274	1070	400	900	1.785,00 €	
1/2"- AREK 6314-B1	405,4	1x4x630	131,2	37045	104,0	26370	84,5	20315	$\emptyset$ 54/ $\emptyset$ 42	4274	1070	400	900	2.140,00 €	
1/2"- AREK 6322-A1	304,0	2x2x630	119,0	38775	94,3	27784	78,9	21800	$\emptyset$ 2x35/ $\emptyset$ 2x28	2275	2030	400	900	1.715,00 €	
1/2"- AREK 6322-B1	405,4	2x2x630	134,5	37050	104,0	26370	84,6	20316	$\emptyset$ 2x35/ $\emptyset$ 2x28	2275	2030	400	900	2.079,00 €	
1/2"- AREK 6323-A1	456,0	2x3x630	177,6	58165	140,3	41674	117,5	32710	$\emptyset$ 2x42/ $\emptyset$ 2x35	3275	2030	400	900	2.468,00 €	
1/2"- AREK 6323-B1	608,0	2x3x630	201,2	55575	156,0	39554	126,7	30472	$\emptyset$ 2x42/ $\emptyset$ 2x35	3275	2030	400	900	3.005,00 €	
1/2"- AREK 6324-A1	608,0	2x4x630	238,4	77550	190,0	55568	159,4	43610	$\emptyset$ 2x42/ $\emptyset$ 2x35	4274	2030	400	900	3.184,00 €	
1/2"- AREK 6324-B1	810,7	2x4x630	262,6	74100	208,1	52740	169,0	40630	$\emptyset$ 2x42/ $\emptyset$ 2x35	4274	2030	400	900	3.894,00 €	
1/2"- AREK 6325-A1	760,0	2x5x630	293,0	96940	236,0	69460	199,3	54520	$\emptyset$ 2x54/ $\emptyset$ 2x42	5275	2030	400	900	3.968,00 €	
1/2"- AREK 6325-B1	1013,4	2x5x630	334,1	92620	258,0	65925	210,0	50790	$\emptyset$ 2x54/ $\emptyset$ 2x42	5275	2030	400	900	4.860,00 €	
1/2"- AREK 6326-A1	912,1	2x6x630	339,1	116325	277,2	83350	235,0	65420	$\emptyset$ 2x54/ $\emptyset$ 2x42	6275	2030	400	900	4.684,00 €	
1/2"- AREK 6326-B1	1216,1	2x6x630	403,2	111145	312,4	79110	254,0	60950	$\emptyset$ 2x54/ $\emptyset$ 2x42	6275	2030	400	900	5.750,00 €	
<b>3228-1/2"</b>															
1/2"- AREK 6312-A5	127,7	1x2x630	55,0	19660	44,1	14117	37,2	11147	$\emptyset$ 35/ $\emptyset$ 28	2275	1070	400	900	930,10 €	
1/2"- AREK 6312-B5	170,3	1x2x630	63,4	18857	49,6	13457	40,1	10444	$\emptyset$ 35/ $\emptyset$ 28	2275	1070	400	900	1.121,46 €	
1/2"- AREK 6313-A5	191,5	1x3x630	82,0	29490	66,4	21177	56,7	16721	$\emptyset$ 42/ $\emptyset$ 35	3275	1070	400	900	1.329,69 €	
1/2"- AREK 6313-B5	255,4	1x3x630	95,0	28286	74,5	20187	61,4	15666	$\emptyset$ 42/ $\emptyset$ 35	3275	1070	400	900	1.584,73 €	
1/2"- AREK 6314-A5	255,4	1x4x630	116,5	42640	89,0	28236	75,4	22295	$\emptyset$ 54/ $\emptyset$ 42	4274	1070	400	900	1.730,19 €	
1/2"- AREK 6314-B5	340,5	1x4x630	125,4	37714	99,3	26916	82,1	20888	$\emptyset$ 54/ $\emptyset$ 42	4275	1070	400	900	2.067,29 €	
1/2"- AREK 6322-A5	255,4	2x2x630	110,0	39320	88,2	28234	74,5	22294	$\emptyset$ 2x35/ $\emptyset$ 2x28	2275	2030	400	900	1.660,19 €	
1/2"- AREK 6322-B5	340,5	2x2x630	126,7	37714	99,3	26914	82,0	20888	$\emptyset$ 2x35/ $\emptyset$ 2x28	2275	2030	400	900	2.006,25 €	
1/2"- AREK 6323-A5	383,1	2x3x630	164,0	58980	133,0	42354	113,2	33442	$\emptyset$ 2x42/ $\emptyset$ 2x35	3275	2030	400	900	2.386,10 €	
1/2"- AREK 6323-B5	510,8	2x3x630	190,0	56570	149,2	40374	122,8	31332	$\emptyset$ 2x42/ $\emptyset$ 2x35	3275	2030	400	900	2.896,21 €	
1/2"- AREK 6324-A5	510,8	2x4x630	233,2	85280	178,1	56472	150,8	44590	$\emptyset$ 2x42/ $\emptyset$ 2x35	4274	2030	400	900	3.075,56 €	
1/2"- AREK 6324-B5	681,0	2x4x630	250,8	75428	198,5	53832	164,3	41776	$\emptyset$ 2x42/ $\emptyset$ 2x35	4275	2030	400	900	3.749,71 €	
1/2"- AREK 6325-A5	638,4	2x5x630	274,0	98300	222,1	70590	188,4	55738	$\emptyset$ 2x54/ $\emptyset$ 2x42	5275	2030	400	900	3.832,56 €	
1/2"- AREK 6325-B5	851,3	2x5x630	315,0	94280	249,0	67290	202,7	52222	$\emptyset$ 2x54/ $\emptyset$ 2x42	5275	2030	400	900	4.679,83 €	
1/2"- AREK 6326-A5	766,1	2x6x630	333,7	117960	268,6	84708	227,8	66886	$\emptyset$ 2x54/ $\emptyset$ 2x42	6275	2030	400	900	4.522,00 €	
1/2"- AREK 6326-B5	1021,5	2x6x630	381,5	113136	300,0	80748	245,7	62666	$\emptyset$ 2x54/ $\emptyset$ 2x42	6275	2030	400	900	5.533,33 €	

**AREK ENDÜSTRİYEL SERİ HAVA SOĞUTMALI KONDANSERLER**  
AREK SERIES INDUSTRIAL AIR COOLED CONDENSER

Lamel Aralığı Fin Spacing	MODEL MODEL	Yüzey Surface	Fan Sayısı Number of Fan	880 rpm Δ 50 Hz-3/400 V			660 rpm Y 50 Hz-3/400 V			330 rpm Y 50 Hz-3/400 V			Boyutlar Dimension			Fiyat Price (Ral 7035)
				Kapasite Capacity	Hava Debisi Air Flow	Kapasite Capacity	Hava Debisi Air Flow	Kapasite Capacity	Hava Debisi Air Flow	Bağlantılar Connections		Ld	Ht	D	Da	
										Giriş (in) Çıkış (Out)	mm					
	1/2"- AREK 8011-A1	115,5	1x1x800	50,0	21800	42,5	16650	25,5	7800	Ø 28/Ø 22	1475	1320	500	1100	787,00 €	
	1/2"- AREK 8011-B1	134,8	1x1x800	55,8	22650	47,0	17475	27,6	8300	Ø 35/Ø 28	1675	1320	500	1100	893,00 €	
	1/2"- AREK 8011-C1	154,0	1x1x800	62,5	21600	49,7	15600	28,0	7255	Ø 35/Ø 28	1475	1320	500	1100	953,00 €	
	1/2"- AREK 8011-D1	179,7	1x1x800	67,4	21650	55,5	16515	31,0	7750	Ø 35/Ø 28	1675	1320	500	1100	1.058,00 €	
	1/2"- AREK 8012-A1	231,1	1x2x800	110,2	41970	95,2	31717	54,6	14400	Ø 42/Ø 35	2675	1320	500	1100	1.426,00 €	
	1/2"- AREK 8012-B1	269,6	1x2x800	122,0	43808	103,5	33459	59,5	15350	Ø 42/Ø 35	3075	1320	500	1100	1.596,00 €	
	1/2"- AREK 8012-C1	308,1	1x2x800	128,3	39415	105,3	29428	57,0	13250	Ø 42/Ø 35	2675	1320	500	1100	1.700,00 €	
	1/2"- AREK 8012-D1	359,4	1x2x800	140,3	41660	115,1	31430	62,0	14250	Ø 54/Ø 42	3075	1320	500	1100	1.937,00 €	
	1/2"- AREK 8013-A1	346,6	1x3x800	170,0	62960	142,7	47578	82,1	21600	Ø 54/Ø 42	3875	1320	500	1100	2.057,00 €	
	1/2"- AREK 8013-B1	404,3	1x3x800	184,2	65714	156,0	50189	89,0	23030	Ø 54/Ø 42	4475	1320	500	1100	2.309,00 €	
	1/2"- AREK 8013-C1	462,1	1x3x800	207,0	59125	158,6	44145	85,3	19980	Ø 54/Ø 42	3875	1320	500	1100	2.462,00 €	
	1/2"- AREK 8013-D1	539,1	1x3x800	208,0	62490	173,0	47146	93,0	21380	Ø 54/Ø 42	4475	1320	500	1100	2.780,00 €	
	1/2"- AREK 8014-A1	462,1	1x4x800	227,0	83945	191,6	63436	109,2	28810	Ø 54/Ø 42	5075	1320	500	1100	3.067,00 €	
	1/2"- AREK 8014-B1	539,1	1x4x800	247,2	87618	208,7	66918	118,4	30715	Ø 66/Ø 54	5875	1320	500	1100	3.660,00 €	
	1/2"- AREK 8014-C1	616,1	1x4x800	257,0	78835	209,2	58819	112,6	26500	Ø 66/Ø 54	5075	1320	500	1100	3.267,00 €	
	1/2"- AREK 8014-D1	718,8	1x4x800	281,4	83320	230,4	62862	123,2	28500	Ø 66/Ø 54	5875	1320	500	1100	3.690,00 €	
	1/2"- AREK 8022-A1	413,5	2x2x800	212,3	80840	177,6	60638	102,0	27370	Ø 2x42/Ø 2x35	2675	2330	500	1100	2.379,00 €	
	1/2"- AREK 8022-B1	482,4	2x2x800	231,4	85040	192,1	64452	111,6	29350	Ø 2x42/Ø 2x35	3075	2330	500	1100	2.673,00 €	
	1/2"- AREK 8022-C1	551,3	2x2x800	239,6	75170	194,8	55708	106,5	25050	Ø 2x42/Ø 2x35	2675	2330	500	1100	2.869,00 €	
	1/2"- AREK 8022-D1	643,2	2x2x800	264,0	80150	215,9	60018	116,7	27070	Ø 2x42/Ø 2x35	3075	2330	500	1100	3.241,00 €	
	1/2"- AREK 8023-A1	620,2	2x3x800	318,0	121290	266,4	90960	153,8	41060	Ø 2x54/Ø 2x42	3875	2330	500	1100	3.420,00 €	
	1/2"- AREK 8023-B1	723,6	2x3x800	345,8	127560	292,8	96678	167,7	44030	Ø 2x54/Ø 2x42	4475	2330	500	1100	3.859,00 €	
	1/2"- AREK 8023-C1	826,9	2x3x800	363,2	112760	294,2	83568	159,7	37580	Ø 2x54/Ø 2x42	3875	2330	500	1100	4.145,00 €	
	1/2"- AREK 8023-D1	964,8	2x3x800	398,8	120330	325,5	90126	174,5	40600	Ø 2x54/Ø 2x42	4475	2330	500	1100	4.702,00 €	
	1/2"- AREK 8024-A1	826,9	2x4x800	427,6	161720	355,7	121282	204,4	54750	Ø 2x54/Ø 2x42	5075	2330	500	1100	4.444,00 €	
	1/2"- AREK 8024-B1	964,8	2x4x800	470,4	170080	393,9	128306	223,3	58705	Ø 2x66/Ø 2x54	5875	2330	500	1100	5.134,00 €	
	1/2"- AREK 8024-C1	1102,6	2x4x800	480,0	150350	390,0	111422	213,6	51000	Ø 2x66/Ø 2x54	5075	2330	500	1100	5.520,00 €	
	1/2"- AREK 8024-D1	1286,3	2x4x800	529,1	160310	432,2	120034	234,0	54135	Ø 2x66/Ø 2x54	5875	2330	500	1100	6.261,00 €	
	1/2"- AREK 8025-A1	1033,7	2x5x800	529,0	202150	441,0	151606	256,2	68440	Ø 2x66/Ø 2x54	6275	2330	500	1100	5.545,00 €	
	1/2"- AREK 8025-B1	1205,9	2x5x800	582,1	212600	488,0	161136	281,6	73380	Ø 2x66/Ø 2x54	7275	2330	500	1100	6.276,00 €	
	1/2"- AREK 8025-C1	1378,2	2x5x800	600,0	187940	490,5	139202	265,4	62630	Ø 2x66/Ø 2x54	6275	2330	500	1100	6.751,00 €	
	1/2"- AREK 8025-D1	1607,9	2x5x800	653,3	200390	538,3	150018	291,7	67670	Ø 2x80/Ø 2x66	7275	2330	500	1100	7.857,00 €	
	1/2"- AREK 8026-A1	1240,4	2x6x800	620,0	242600	533,5	181926	309,1	82130	Ø 2x80/Ø 2x66	7475	2330	500	1100	6.721,00 €	
	1/2"- AREK 8026-B1	1447,1	2x6x800	691,0	255120	585,0	173362	338,0	88060	Ø 2x80/Ø 2x66	8675	2330	500	1100	8.059,00 €	
	1/2"- AREK 8026-C1	1653,9	2x6x800	709,0	225520	583,6	167136	319,8	75150	Ø 2x80/Ø 2x66	7475	2330	500	1100	8.690,00 €	
	1/2"- AREK 8026-D1	1929,5	2x6x800	782,4	240470	637,2	18800	349,4	81200	Ø 2x80/Ø 2x66	8675	2330	500	1100	9.888,00 €	

2,1 mm Hâbe / Fin Spacing

**AREK ENDÜSTRİYEL SERİ HAVA SOĞUTMALI KONDANSERLER**  
AREK SERIES INDUSTRIAL AIR COOLED CONDENSER

Lamel Aralığı Fin Spacing	MODEL MODEL	Yüzey Surface	Fan Sayısı Number of Fan	880 rpm Δ 50 Hz-3/400 V		660 rpm Y 50 Hz-3/400 V		330 rpm Y 50 Hz-3/400 V		Bağlantılar Connections	Boyutlar Dimension			Fiyat Price (Ral 7035)		
				Kapasite Capacity	Hava Debisi Air Flow	Kapasite Capacity	Hava Debisi Air Flow	Kapasite Capacity	Hava Debisi Air Flow		Giriş (in) Çıkış (Out)	Ld	Ht		D	Da
	1/2"- AREK 8011-A5	97,0	1x1x800	44,9	21900	38,1	16750	22,9	7900	Ø 28/Ø 22	1475	1320	500	1100	766,00 €	
	1/2"- AREK 8011-B5	113,2	1x1x800	50,9	22750	43,2	17575	25,9	8400	Ø 35/Ø 28	1675	1320	500	1100	869,00 €	
	1/2"- AREK 8011-C5	129,4	1x1x800	55,9	21700	46,3	15700	26,4	7355	Ø 35/Ø 28	1475	1320	500	1100	925,00 €	
	1/2"- AREK 8011-D5	151,0	1x1x800	62,5	17100	51,8	16615	29,3	7850	Ø 35/Ø 28	1675	1320	500	1100	1.026,00 €	
	1/2"- AREK 8012-A5	194,1	1x2x800	101,6	42775	85,4	32470	50,4	14815	Ø 42/Ø 35	2675	1320	500	1100	1.385,00 €	
	1/2"- AREK 8012-B5	226,4	1x2x800	112,3	44470	94,9	34115	55,3	15740	Ø 42/Ø 35	3075	1320	500	1100	1.548,00 €	
	1/2"- AREK 8012-C5	258,8	1x2x800	120,7	40390	99,3	30290	55,1	13680	Ø 42/Ø 35	2675	1320	500	1100	1.646,00 €	
	1/2"- AREK 8012-D5	301,9	1x2x800	132,3	42485	109,5	32200	60,3	14670	Ø 54/Ø 42	3075	1320	500	1100	1.873,00 €	
	1/2"- AREK 8013-A5	291,1	1x3x800	157,3	64165	132,9	48710	77,5	22225	Ø 54/Ø 42	3875	1320	500	1100	1.995,00 €	
	1/2"- AREK 8013-B5	339,6	1x3x800	170,8	66710	145,4	51177	85,0	23610	Ø 54/Ø 42	4475	1320	500	1100	2.237,00 €	
	1/2"- AREK 8013-C5	388,2	1x3x800	179,8	60585	149,6	45435	83,4	29520	Ø 54/Ø 42	3875	1320	500	1100	2.380,00 €	
	1/2"- AREK 8013-D5	452,9	1x3x800	195,0	63730	161,8	48300	90,7	22000	Ø 54/Ø 42	4475	1320	500	1100	2.684,00 €	
	1/2"- AREK 8014-A5	388,2	1x4x800	205,6	85550	175,8	64945	104,5	29630	Ø 66/Ø 54	5075	1320	500	1100	2.585,00 €	
	1/2"- AREK 8014-B5	452,9	1x4x800	230,3	88950	189,9	68237	113,4	31480	Ø 66/Ø 54	5875	1320	500	1100	2.965,00 €	
	1/2"- AREK 8014-C5	517,6	1x4x800	241,7	80780	198,8	60584	110,2	27360	Ø 66/Ø 54	5075	1320	500	1100	3.158,00 €	
	1/2"- AREK 8014-D5	603,8	1x4x800	265,1	84980	219,2	64404	120,5	29340	Ø 66/Ø 54	5875	1320	500	1100	3.563,00 €	
	1/2"- AREK 8022-A5	347,3	2x2x800	196,4	82670	165,4	62280	93,8	28220	Ø 2x42/Ø 2x35	2675	2330	500	1100	2.305,00 €	
	1/2"- AREK 8022-B5	405,2	2x2x800	214,2	86560	182,4	65906	103,5	30160	Ø 2x42/Ø 2x35	3075	2330	500	1100	2.587,00 €	
	1/2"- AREK 8022-C5	463,1	2x2x800	223,8	77300	185,2	57552	105,8	25900	Ø 2x42/Ø 2x35	2675	2330	500	1100	2.771,00 €	
	1/2"- AREK 8022-D5	540,3	2x2x800	248,2	82020	204,5	61690	113,0	27920	Ø 2x42/Ø 2x35	3075	2330	500	1100	3.127,00 €	
	1/2"- AREK 8023-A5	521,0	2x3x800	294,4	124000	248,6	95424	145,3	42330	Ø 2x54/Ø 2x42	3875	2330	500	1100	3.310,00 €	
	1/2"- AREK 8023-B5	607,8	2x3x800	321,0	129850	273,0	98862	155,4	45240	Ø 2x54/Ø 2x42	4475	2330	500	1100	3.731,00 €	
	1/2"- AREK 8023-C5	694,6	2x3x800	339,0	116000	278,6	86332	156,1	38850	Ø 2x54/Ø 2x42	3875	2330	500	1100	3.999,00 €	
	1/2"- AREK 8023-D5	810,4	2x3x800	367,5	123030	310,0	92538	170,0	41880	Ø 2x54/Ø 2x42	4475	2330	500	1100	4.531,00 €	
	1/2"- AREK 8024-A5	694,6	2x4x800	395,8	165350	331,5	124566	195,5	56440	Ø 2x54/Ø 2x42	5075	2330	500	1100	4.297,00 €	
	1/2"- AREK 8024-B5	810,4	2x4x800	431,5	173130	365,4	131816	213,2	60320	Ø 2x66/Ø 2x54	5875	2330	500	1100	4.963,00 €	
	1/2"- AREK 8024-C5	926,2	2x4x800	451,4	154640	371,0	115112	205,2	51800	Ø 2x66/Ø 2x54	5075	2330	500	1100	5.324,00 €	
	1/2"- AREK 8024-D5	1080,5	2x4x800	498,5	16405	411,5	123386	226,1	55840	Ø 2x66/Ø 2x54	5875	2330	500	1100	6.033,00 €	
	1/2"- AREK 8025-A5	868,3	2x5x800	488,2	206690	419,2	155710	242,0	70550	Ø 2x66/Ø 2x54	6275	2330	500	1100	5.361,00 €	
	1/2"- AREK 8025-B5	1013,0	2x5x800	538,1	216420	459,7	164772	261,0	75400	Ø 2x66/Ø 2x54	7275	2330	500	1100	6.062,00 €	
	1/2"- AREK 8025-C5	1157,7	2x5x800	567,4	193300	468,0	143892	259,1	64760	Ø 2x66/Ø 2x54	6275	2330	500	1100	6.506,00 €	
	1/2"- AREK 8025-D5	1350,7	2x5x800	617,6	205060	513,9	154234	285,1	69800	Ø 2x80/Ø 2x66	7275	2330	500	1100	7.572,00 €	
	1/2"- AREK 8026-A5	1041,9	2x6x800	589,7	248030	497,7	186494	283,5	84660	Ø 2x80/Ø 2x66	7475	2330	500	1100	6.501,00 €	
	1/2"- AREK 8026-B5	1215,6	2x6x800	643,0	259700	546,6	197728	302,0	90490	Ø 2x80/Ø 2x66	8675	2330	500	1100	7.802,00 €	
	1/2"- AREK 8026-C5	1389,2	2x6x800	672,0	231960	558,4	172672	312,5	77700	Ø 2x80/Ø 2x66	7475	2330	500	1100	8.396,00 €	
	1/2"- AREK 8026-D5	1620,8	2x6x800	735,0	246070	606,8	185082	342,0	83750	Ø 2x80/Ø 2x66	8675	2330	500	1100	9.545,00 €	

2,5 mm Hâbe / Fin Spacing

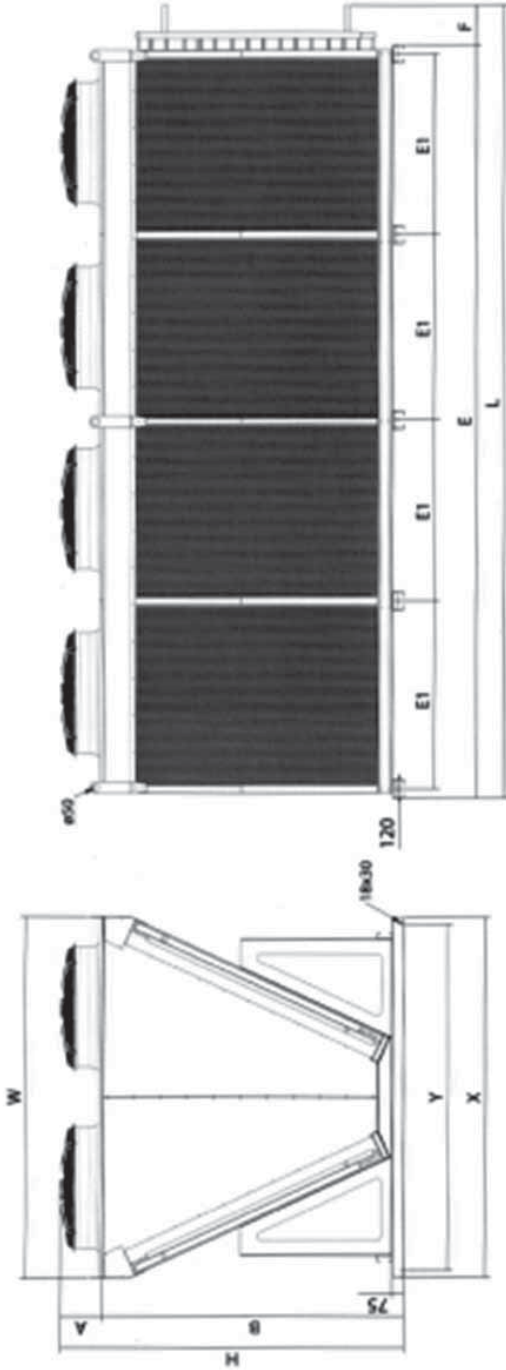

### ARK V TİPİ KONDANSER

ARK V TYPE SCONDENSING

Lamel Aralığı / Fin Spacing	MODEL MODEL	Yüzey Surface m <sup>2</sup>	Fan Sayısı Number of Fan	880 rpm Δ 50 Hz-3/400 V 1 Fan için Akım ve Güç değerleri Current and Power rate for 1 Fan I : 4,00 Amp P : 2,00 kW		660 rpm Δ 50 Hz-3/400 V 1 Fan için Akım ve Güç değerleri Current and Power rate for 1 Fan I : 2,30 Amp P : 1,25 kW		340 rpm Y 50 Hz-3/400 V 1 Fan için Akım ve Güç değerleri Current and Power rate for 1 Fan I : 0,60 Amp P : 0,20 kW		Bağlantılar Connections				Boyutlar Dimension			Fiyat Price (Ral 7035) €
				Kapasite Capacity kwatt	Hava Debisi Air Flow m <sup>3</sup> /h	Kapasite Capacity kwatt	Hava Debisi Air Flow m <sup>3</sup> /h	Kapasite Capacity kwatt	Hava Debisi Air Flow m <sup>3</sup> /h	Giriş (in) mm	Çıkış (Out) mm	Ld mm	B mm	W mm	X mm		
2,1 mm Hava / Fin Spacing	3/8"- ARSBVK 8012-A1	356,3	1x2x800	153,4	44705	122,2	33225	81,8	17535	Ø 35/Ø 28	2800	1500	1.185	1170	2.592,00 €		
	3/8"- ARSBVK 8012-B1	475,1	1x2x800	170,6	43360	133,8	32265	85,3	16690	Ø 35/Ø 28	2800	1500	1.185	1170	3.122,00 €		
	3/8"- ARSBVK 8013-A1	534,4	1x3x800	228,4	67060	182,7	49840	108,5	26300	Ø 42/Ø 35	4025	1500	1.185	1170	3.775,00 €		
	3/8"- ARSBVK 8013-B1	712,6	1x3x800	254,7	65045	200,3	48395	112,8	25035	Ø 42/Ø 35	4025	1500	1.185	1170	4.556,00 €		
	3/8"- ARSBVK 8014-A1	712,6	1x4x800	307,5	89410	244,9	66450	144,7	35065	Ø 42/Ø 35	5250	1500	1.185	1170	4.997,00 €		
	3/8"- ARSBVK 8014-B1	950,1	1x4x800	341,8	86725	267,9	64525	150,4	33375	Ø 54/Ø 42	5250	1500	1.185	1170	6.095,00 €		
	3/8"- ARSBVK 8022-A1	534,4	2x2x800	272,3	84595	219,7	63020	128,9	32250	Ø 2x35/Ø 2x28	2800	2000	2.400	2400	4.127,00 €		
	3/8"- ARSBVK 8022-B1	712,6	2x2x800	303,8	80895	240,6	60260	133,3	30190	Ø 2x35/Ø 2x28	2800	2000	2.400	2400	4.920,00 €		
	3/8"- ARSBVK 8023-A1	801,7	2x3x800	403,9	126895	327,5	94530	193,3	48375	Ø 2x42/Ø 2x35	4025	2000	2.400	2400	5.989,00 €		
	3/8"- ARSBVK 8023-B1	1068,9	2x3x800	452,2	121340	359,5	90395	200,1	45285	Ø 2x42/Ø 2x35	4025	2000	2.400	2400	7.158,00 €		
2,5 mm Hava / Fin Spacing	3/8"- ARSBVK 8012-A5	299,3	1x2x800	143,1	45120	114,7	33555	69,1	17815	Ø 35/Ø 28	2800	1500	1.185	1170	2.533,00 €		
	3/8"- ARSBVK 8012-B5	399,1	1x2x800	162,1	43870	127,9	32640	73,6	17065	Ø 35/Ø 28	2800	1500	1.185	1170	3.043,00 €		
	3/8"- ARSBVK 8013-A5	448,9	1x3x800	213,4	67680	171,7	50335	103,8	26720	Ø 42/Ø 35	4025	1500	1.185	1170	3.687,00 €		
	3/8"- ARSBVK 8013-B5	598,6	1x3x800	242,3	65310	191,7	48960	110,6	25595	Ø 42/Ø 35	4025	1500	1.185	1170	4.438,00 €		
	3/8"- ARSBVK 8014-A5	598,6	1x4x800	286,7	90240	229,7	67115	138,3	35625	Ø 42/Ø 35	5250	1500	1.185	1170	4.880,00 €		
	3/8"- ARSBVK 8014-B5	798,1	1x4x800	324,7	87745	256,1	65280	147,4	34125	Ø 54/Ø 42	5250	1500	1.185	1170	5.938,00 €		
	3/8"- ARSBVK 8022-A5	448,9	2x2x800	253,8	85750	205,5	63770	122,7	32810	Ø 2x35/Ø 2x28	2800	2000	2.400	2400	4.039,00 €		
	3/8"- ARSBVK 8022-B5	598,6	2x2x800	288,5	82280	229,0	61265	130,3	30935	Ø 2x35/Ø 2x28	2800	2000	2.400	2400	4.803,00 €		
	3/8"- ARSBVK 8023-A5	673,4	2x3x800	377,4	128630	306,8	95660	184,2	49220	Ø 2x42/Ø 2x35	4025	2000	2.400	2400	5.857,00 €		
	3/8"- ARSBVK 8023-B5	897,9	2x3x800	430,1	123420	343,8	91895	195,8	46410	Ø 2x42/Ø 2x35	4025	2000	2.400	2400	6.982,00 €		

**ARVK V TİPİ KONDANSER**  
ARVK V TYPE SCODENSING

Lamel Aralığı / Fin Spacing	MODEL MODEL	Yüzey Surface	Fan Sayısı Number of Fan	880 rpm $\Delta$ 50 Hz-3/400 V		660 rpm $\gamma$ 50 Hz-3/400 V		340 rpm $\gamma$ 50 Hz-3/400 V		Bağlantılar Connections	Boyutlar Dimension				Fiyat Price (Ral/ 7035)
				Kapasite Capacity	Hava Debisi Air Flow	Kapasite Capacity	Hava Debisi Air Flow	Kapasite Capacity	Hava Debisi Air Flow		Ld	H	W	X	
		m <sup>2</sup>	n	kwatt	m <sup>3</sup> /h	kwatt	m <sup>3</sup> /h	kwatt	m <sup>3</sup> /h	mm	mm	mm	mm	mm	€

**3228-1/2"**

2,1 mm Havle / Fin Spacing	1/2"- ARVK 8012-A1	558,4	1x2x800	172,2	45680	136,7	34020	80,6	18190	Ø 42/Ø 35	2800	1780	1.185	1170	3.541,00 €
	1/2"- ARVK 8012-B1	744,5	1x2x800	188,5	44670	146,8	33225	82,6	17535	Ø 42/Ø 35	2800	1780	1.185	1170	4.366,00 €
	1/2"- ARVK 8013-A1	837,6	1x3x800	260,3	68515	207,0	51030	120,9	27285	Ø 54/Ø 42	4025	1780	1.185	1170	5.264,00 €
	1/2"- ARVK 8013-B1	1116,8	1x3x800	284,0	66990	221,0	49840	123,9	26300	Ø 54/Ø 42	4025	1780	1.185	1170	6.501,00 €
	1/2"- ARVK 8014-A1	1116,8	1x4x800	348,8	91355	275,2	68035	160,9	35375	Ø 54/Ø 42	6250	1780	1.185	1170	8.849,00 €
	1/2"- ARVK 8014-B1	1489,0	1x4x800	379,5	89320	294,4	66450	164,9	35065	Ø 66/Ø 54	6250	1780	1.185	1170	8.595,00 €
	1/2"- AREK 8022-A1	822,9	2x2x800	313,0	87280	249,5	64860	145,1	33750	Ø 2x42/Ø 2x35	3300	2280	2.400	2400	5.222,00 €
	1/2"- ARVK 8022-B1	1097,2	2x2x800	342,5	84135	268,0	62600	147,5	31875	Ø 2x42/Ø 2x35	3300	2280	2.400	2400	6.434,00 €
	1/2"- ARVK 8023-A1	1234,3	2x3x800	467,0	130920	373,2	97300	217,9	50625	Ø 2x54/Ø 2x42	4775	2280	2.400	2400	7.726,00 €
	1/2"- ARVK 8023-B1	1645,8	2x3x800	512,0	126200	401,8	93905	221,6	47815	Ø 2x54/Ø 2x42	4775	2280	2.400	2400	9.546,00 €
	1/2"- ARVK 8024-A1	1645,8	2x4x800	627,0	174560	499,2	129720	290,2	67500	Ø 2x54/Ø 2x42	6250	2280	2.400	2400	10.042,00 €
	1/2"- ARVK 8024-B1	2194,3	2x4x800	685,7	168270	536,5	125205	295,1	63750	Ø 2x66/Ø 2x54	6250	2280	2.400	2400	12.628,00 €
	1/2"- ARVK 8025-A1	2057,2	2x5x800	771,6	218200	619,1	162150	363,1	84375	Ø 2x66/Ø 2x54	7725	2280	2.400	2400	12.533,00 €
	1/2"- ARVK 8025-B1	2742,9	2x5x800	848,6	210330	667,7	156505	369,4	79700	Ø 2x66/Ø 2x54	7725	2280	2.400	2400	15.517,00 €

2,5 mm Havle / Fin Spacing	1/2"- ARVK 8012-A5	469,0	1x2x800	162,5	45980	129,9	34225	77,9	18375	Ø 42/Ø 35	2800	1780	1.185	1170	3.428,00 €
	1/2"- ARVK 8012-B5	625,4	1x2x800	181,3	45075	142,0	33515	81,6	17815	Ø 42/Ø 35	2800	1780	1.185	1170	4.216,00 €
	1/2"- ARVK 8013-A5	703,6	1x3x800	245,4	68965	195,4	51340	116,6	27565	Ø 54/Ø 42	4025	1780	1.185	1170	5.095,00 €
	1/2"- ARVK 8013-B5	938,1	1x3x800	272,5	67610	213,5	50275	122,3	26720	Ø 54/Ø 42	4025	1780	1.185	1170	6.276,00 €
	1/2"- ARVK 8014-A5	938,1	1x4x800	328,0	91955	260,5	68455	153,6	36750	Ø 54/Ø 42	6250	1780	1.185	1170	6.624,00 €
	1/2"- ARVK 8014-B5	1250,8	1x4x800	364,3	90150	284,4	67035	162,7	35625	Ø 66/Ø 54	6250	1780	1.185	1170	8.296,00 €
	1/2"- AREK 8022-A5	691,2	2x2x800	293,5	88205	235,6	65610	139,9	34310	Ø 2x42/Ø 2x35	3300	2280	2.400	2400	5.056,00 €
	1/2"- ARVK 8022-B5	921,6	2x2x800	327,8	85335	258,6	63520	145,8	32625	Ø 2x42/Ø 2x35	3300	2280	2.400	2400	6.214,00 €
	1/2"- ARVK 8023-A5	1036,8	2x3x800	438,5	132305	353,0	98415	210,3	51470	Ø 2x54/Ø 2x42	4775	2280	2.400	2400	7.478,00 €
	1/2"- ARVK 8023-B5	1382,4	2x3x800	490,5	128000	388,0	95280	219,3	48940	Ø 2x54/Ø 2x42	4775	2280	2.400	2400	9.215,00 €
	1/2"- ARVK 8024-A5	1382,4	2x4x800	587,7	176410	471,6	131220	279,9	68625	Ø 2x54/Ø 2x42	6250	2280	2.400	2400	9.711,00 €
	1/2"- ARVK 8024-B5	1843,2	2x4x800	656,1	170670	517,6	127040	291,6	65250	Ø 2x66/Ø 2x54	6250	2280	2.400	2400	12.186,00 €
	1/2"- ARVK 8025-A5	1728,0	2x5x800	726,0	220510	586,4	164030	350,6	85780	Ø 2x66/Ø 2x54	7725	2280	2.400	2400	12.119,00 €
	1/2"- ARVK 8025-B5	2304,1	2x5x800	814,1	213335	645,3	158800	365,6	81560	Ø 2x66/Ø 2x54	7725	2280	2.400	2400	14.965,00 €

## STANDART SOĞUK ODA EVAPORATÖRLERİ

STANDART UNIT AIR COLLERS



Ürünlerimiz 4-6-8-10 mm hatveli olarak üretilmektedir.

*Units are designed with 4-6-8-10 mm fin distances.*

### Ürünlerin Genel Özellikleri:

- \*Bataryalar bakır boru üzerine alüminyum lamel malzemesi dizilerek oluşturulur.
- \*Ayna sacı olarak alüminyum malzeme kullanılır.
- \*Kasetleme sistemi elektrostatik toz boyalı galvaniz sacıdan oluşturulmuştur.
- \*Kullanım şartlarına ve isteğe göre E1 ve E2 defrost sistemi
- \*Evaporatörlerin kasaları standart olarak RAL 7035 elektrostatik toz boyalıdır.

#### General Product Properties:

- \*Coils are made with copper tubes and aluminium fins*
- \*End-plates are made of aluminium*
- \*Casing is coated with electro-staticly powder painted*
- \*E1 and E2 type of heater are considered*

### Opsiyonlar:

- \*Boru tipi olarak Yivli Boru seçeneği
- \*Lamel malzemesi olarak kaplamalı alüminyum fin veya bakır fin seçeneği
- \*Ayna sacı ve kasetleme sisteminde paslanmaz sac seçeneği
- \*Defrost sistemi için ek rezistans seçeneği
- \*Ebm ,Ziehl-Abegg veya muadili fan seçeneği
- \*Komple daldırma epoksi boya kaplama seçeneği

#### Options:

- \*Inner Grooved copper tubes are available*
- \*Pre-coated aluminium fins and copper fins are available*
- \*Casing can be made of stainless steel sheet metal*
- \*Additional heaters*
- \*Choice of Ebm,Ziehl-Abegg or equivalent fan*
- \*Whole body epoxy coating with dipping*

## TEKNİK BİLGİLER

### TECHNISCHE SPECIFICATIONS

Katalogumuzda vermiş olduğumuz kapasite değerleri R404A gazı için Eurovent standart şartları (EN 328) ile hesaplanmıştır. Farklı gaz ,lamel malzemesi veya sıcaklık şartları kullanılması durumunda aşağıda belirtilen düzeltme şartları kullanılarak istenilen soğutma kapasitesi SC' şartlarına uyarlanarak cihaz seçimi yapılır.

Capacities given in our catalogue are calculated according to with R404A gas and Eurovent (EN 328) conditions. If the gas fin material or temperature values are different, selection of Unit Coolers are possibly made by utilizing different, correction factors and by obtaining capacities in terms of SC2 values

Standart Şartlar Standart Conditions	Oda Sıcaklığı Room Temperature	Evaporasyon Sıcaklığı Evaporation Temperature	$\Delta T$
SC1	10	0	10
SC2	0	-8	8
SC3	-18	-25	7
SC4	-25	-31	6
SC5	-38	-40	5

Oda bağıl neminin  $\Delta T$  sıcaklık farkına göre değişimi  
Change of relative humidity in ambient in regard to  $\Delta T$

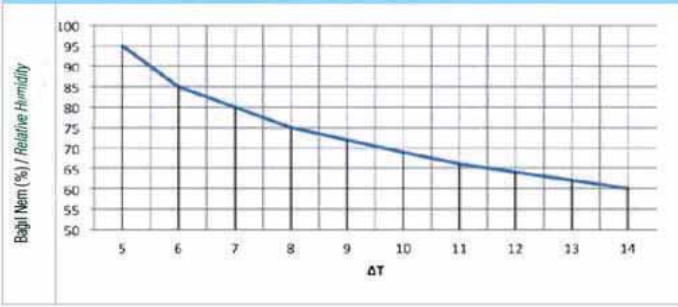

Oda sıcaklığına bağlı olarak tavsiye edilen lamel aralıkları  
Recommended efficient fin spacing to room temperatures

	4	6	8	10	12
SC1	√	√			
SC2	√	√	√		
SC3		√	√	√	
SC4			√	√	
SC5					√

Düzeltilme Faktörleri / Correction Factors / Korrektur Faktor	
<b>11 Sıcaklık düzeltme faktörü</b> Temperature correction factor Oda sıcaklığı / Room temp.	
Oda sıcaklığı / Room temp.	
	-35 -30 -25 -20 -15 -10 -5 0 5 10 15
5	1,92 1,89 1,85 1,82 1,75 1,69 1,67 1,61 1,39 1,37 1,19
6	1,59 1,54 1,52 1,49 1,43 1,41 1,39 1,41 1,16 1,14 1,12
7	1,3 1,27 1,23 1,2 1,18 1,15 0,99 0,97 0,96
8	1,15 1,12 1,08 1,05 1,03 1 0,86 0,83 0,83
9	1,01 0,96 0,94 0,91 0,89 0,77 0,74 0,74
10	0,86 0,85 0,83 0,8 0,69 0,68 0,67
11	0,77 0,75 0,72 0,63 0,6 0,59
12	0,71 0,69 0,65 0,57 0,55 0,55
13	0,66 0,62 0,54 0,53 0,52
14	0,64 0,6 0,52 0,51 0,51
<b>12 Soğutucu faktörü</b> Refrigerant Factor	
	SC1 SC2 SC3 SC4
R404A	1,00 1,00 1,00 1,00
R22	0,97 0,97 0,97 0,97
R407C	1,02 1,02 1,02 1,02
R134A	0,93 0,91 0,85 -
R507	1,00 1,00 1,00 1,00
<b>13 Lamel malzemesi düzeltme faktörü</b> Fin material correction factor	
	Alüminyum Kaplı Alüminyum Bakır Aluminium Coated Aluminium Copper
	1,00 0,97 1,03

Düzeltilme faktörlerinin kullanılması The use of correction factors	
$Q_{katalog} = (Q \times f1) / (f2 \times f3)$	
İstenilen Soğutma Kapasitesi	Q 10.000 W
Oda Sıcaklığı	t oda -5°C
Evaporasyon Sıcaklığı	t evap. -12°C
Soğutucu Akışkan	R404A
Lamel Malzemesi	Alüminyum
$\Delta T = t_{oda} - t_{evap.} = (-5) - (-12) = 7°C$	
Sıcaklık Düzeltme Faktörü	f1 1,18
Soğutucu Faktörü	f2 1,00
Lamel Malzemesi Faktörü	f3 1,00
$Q_{katalog} = (10.000 \times 1,18) / (1,00 \times 1,00)$	
$Q_{katalog} = 11.800 \text{ Watt}$	



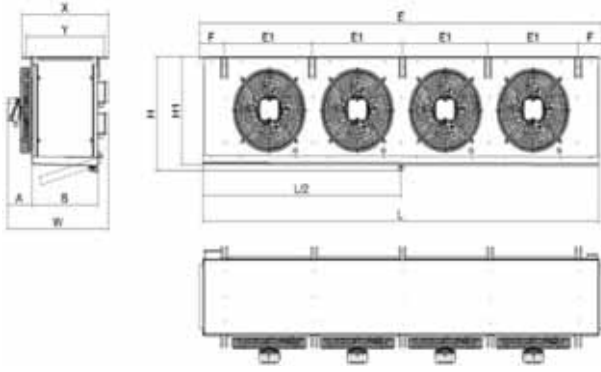

### 6 ARTEV SOĞUK ODA EVAPORATÖRLERİ 6 ARTEV COLD ROOM EVAPORATOR

Lamel Aralığı Fin Spacing	MODEL MODEL	Isı Transfer Alanı Heat Transfer Area	Kapasite Capacity (R 404 A)				Fan Çapı Fan Diameter	Hava Debisi Air Flow Rate	Defrost Isıtıcı Heater			Boyutlar Dimension			Fiyat Price		
			Watt						Batarya coil	Batarya coil	Tava Drainer				Rezistansız Without Resistance	E1 Rezistanslı With E1 Resistance	E2 Rezistanslı With E2 Resistance
			Te=0 °C To=+10 °C	Te=-8 °C To=0 °C	Te=-25 °C To=-18 °C	Te=-31 °C To=-25 °C						L	B	H1			
			m <sup>2</sup>	mm	m <sup>3</sup> /h	Waat			Waat	Waat	mm	mm	mm	€	€	€	
<b>4035-1/2"</b>																	
6 mm Fin Spacing	ARTEV 4016 A	16,8	5490	3970	2990	2250	1x400	3750	5x350	5x350	2x350	1025	360	705	249,00 €	285,00 €	300,00 €
	ARTEV 4016 B	25,2	7715	5340	3890	2890	1x400	3450	7x350	7x350	2x350	1025	360	705	310,00 €	361,00 €	376,00 €
	ARTEV 4026 A	33,6	11030	7985	6075	4605	2x400	7400	5x700	5x700	2x700	1675	360	705	402,00 €	455,00 €	476,00 €
	ARTEV 4026 B	50,4	15010	10115	7790	6030	2x400	6700	7x700	7x700	2x700	1675	360	705	522,00 €	596,00 €	618,00 €
	ARTEV 4036 A	50,4	17080	12100	9020	6810	3x400	11075	6x1000	6x1000	2x1000	2325	360	735	570,00 €	654,00 €	682,00 €
	ARTEV 4036 B	75,7	23600	16380	12450	9380	3x400	10400	8x1000	8x1000	2x1000	2325	360	735	768,00 €	880,00 €	907,00 €
	ARTEV 4046 A	62,1	21150	15250	11885	8900	4x400	14450	6x1250	6x1250	2x1250	2775	360	735	726,00 €	823,00 €	855,00 €
ARTEV 4046 B	93,1	29640	20530	15100	11345	4x400	13450	7x1250	7x1250	2x1250	2775	360	735	913,00 €	1.026,00 €	1.059,00 €	
6 mm Fin Spacing	ARTEV 4516 A	25,2	8310	5760	4190	3130	1x450	4150	8x350	8x350	2x350	1025	360	705	305,00 €	363,00 €	378,00 €
	ARTEV 4516 B	33,6	9770	6600	5050	3870	1x450	3900	9x350	9x350	2x350	1025	440	705	378,00 €	444,00 €	459,00 €
	ARTEV 4526 A	50,4	16150	11340	8650	6590	2x450	8100	7x700	7x700	2x700	1675	360	705	527,00 €	601,00 €	622,00 €
	ARTEV 4526 B	67,2	19670	13745	10250	7865	2x450	7400	9x700	9x700	2x700	1675	440	705	648,00 €	744,00 €	765,00 €
	ARTEV 4536 A	75,7	25600	17740	13620	10170	3x450	12350	8x1000	8x1000	2x1000	2325	360	735	768,00 €	880,00 €	907,00 €
	ARTEV 4536 B	100,9	30525	21100	15775	11820	3x450	11550	9x1000	9x1000	2x1000	2325	440	735	947,00 €	1.072,00 €	1.100,00 €
	ARTEV 4546 A	93,1	32000	22100	16130	12350	4x450	16000	8x1250	8x1250	2x1250	2775	360	735	835,00 €	965,00 €	997,00 €
ARTEV 4546 B	124,1	37430	25845	18250	14330	4x450	14750	10x1250	10x1250	2x1250	2775	440	735	1.044,00 €	1.206,00 €	1.238,00 €	
6 mm Fin Spacing	ARTEV 5016 A	35,5	11960	8630	6620	4980	1x500	6650	9x450	9x450	2x450	1175	375	785	349,00 €	422,00 €	446,00 €
	ARTEV 5016 B	47,3	15010	10365	7720	5730	1x500	6100	11x450	11x450	2x450	1175	450	785	455,00 €	544,00 €	569,00 €
	ARTEV 5026 A	70,9	25500	17570	13150	9980	2x500	13300	10x850	10x850	2x850	1975	375	785	628,00 €	749,00 €	786,00 €
	ARTEV 5026 B	94,6	30280	21000	15780	11820	2x500	12150	12x850	12x850	2x850	1975	450	785	831,00 €	977,00 €	1.013,00 €
	ARTEV 5036 A	106,4	36160	26140	20400	15300	3x500	19900	10x1250	10x1250	2x1250	2775	375	815	925,00 €	1.087,00 €	1.136,00 €
	ARTEV 5036 B	141,9	44550	31160	23620	18030	3x500	18250	12x1250	12x1250	2x1250	2775	450	815	1.154,00 €	1.348,00 €	1.397,00 €
	ARTEV 5046 A	141,9	51350	35400	26610	20260	4x500	26450	10x1650	10x1650	2x1650	3575	375	815	1.230,00 €	1.432,00 €	1.493,00 €
ARTEV 5046 B	189,2	60950	42240	31910	23985	4x500	24250	12x1650	12x1650	2x1650	3575	450	815	1.529,00 €	1.771,00 €	1.832,00 €	

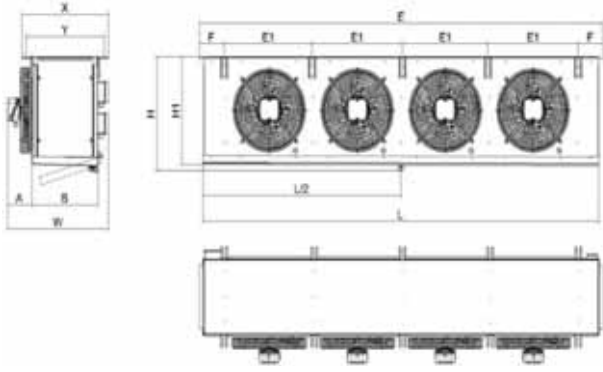

### 8 ARTEV SOĞUK ODA EVAPORATÖRLERİ 8 ARTEV COLD ROOM EVAPORATOR

Lamel Aralığı Fin Spacing	MODEL MODEL	Isı Transfer Alanı Heat Transfer Area	Kapasite Capacity (R 404 A)				Fan Çapı Fan Diameter	Hava Debisi Air Flow Rate	Defrost Isıtıcı Heater			Boyutlar Dimension			Fiyat Price		
			Watt						Batarya coil	Batarya coil	Tava Drainer				Rezistansız Without Resistance	E1 Rezistanslı With E1 Resistance	E2 Rezistanslı With E2 Resistance
			SC1	SC2	SC3	SC4						L	B	H1			
			m <sup>2</sup>	Te=0 °C	To=+10 °C	Te=-8 °C			To=0 °C	Te=-25 °C	To=-18 °C	Te=-31 °C	To=-25 °C	mm	mm	mm	€

#### 4035-1/2"

8 mm Fin Spacing	ARTEV 4018 A	12,6	4840	3315	2580	2010	1x400	3700	6x350	6x350	2x350	1025	360	705	211,00 €	255,00 €	269,00 €
	ARTEV 4018 B	18,9	6670	4570	3415	2650	1x400	3600	8x350	8x350	2x350	1025	360	705	270,00 €	328,00 €	343,00 €
	ARTEV 4028 A	25,2	9800	6700	4300	3245	2x400	7500	6x700	6x700	2x700	1675	360	705	344,00 €	407,00 €	429,00 €
	ARTEV 4028 B	37,8	12955	8880	6595	5130	2x400	6800	8x700	8x700	2x700	1675	360	705	460,00 €	545,00 €	566,00 €
	ARTEV 4038 A	37,8	14615	10005	7640	5890	3x400	11200	6x1000	6x1000	2x1000	2325	360	735	492,00 €	575,00 €	603,00 €
	ARTEV 4038 B	56,7	21115	14225	10295	7945	3x400	10500	8x1000	8x1000	2x1000	2325	360	735	684,00 €	795,00 €	823,00 €
	ARTEV 4048 A	46,6	19045	13055	10160	8090	4x400	14650	6x1250	6x1250	2x1250	2775	360	735	634,00 €	731,00 €	763,00 €
	ARTEV 4048 B	69,8	26125	18585	13635	11075	4x400	13800	8x1250	8x1250	2x1250	2775	360	735	813,00 €	943,00 €	975,00 €

8 mm Fin Spacing	ARTEV 4518 A	18,9	7210	4940	3760	2905	1x450	4250	8x350	8x350	2x350	1025	360	705	265,00 €	323,00 €	338,00 €
	ARTEV 4518 B	25,2	8495	5830	4305	3495	1x450	3950	10x350	10x350	2x350	1025	440	705	332,00 €	406,00 €	420,00 €
	ARTEV 4528 A	37,8	14375	9850	7495	5790	2x450	8400	8x700	8x700	2x700	1675	360	705	465,00 €	549,00 €	571,00 €
	ARTEV 4528 B	50,4	16840	12040	8560	6905	2x450	7650	10x700	10x700	2x700	1675	440	705	577,00 €	683,00 €	704,00 €
	ARTEV 4538 A	56,7	21620	14810	11280	8715	3x450	12700	9x1000	9x1000	2x1000	2325	360	735	684,00 €	809,00 €	837,00 €
	ARTEV 4538 B	75,7	27270	19370	14165	11505	3x450	11900	9x1000	9x1000	2x1000	2325	440	735	850,00 €	975,00 €	1.002,00 €
	ARTEV 4548 A	69,8	28455	19600	14870	11965	4x450	16450	8x1250	8x1250	2x1250	2775	360	735	813,00 €	943,00 €	975,00 €
	ARTEV 4548 B	93,1	33295	23780	17045	13770	4x450	15350	10x1250	10x1250	2x1250	2775	440	735	1.015,00 €	1.186,00 €	1.209,00 €

8 mm Fin Spacing	ARTEV 5018 A	26,6	10405	7125	5225	4000	1x500	6875	9x450	9x450	2x450	1175	375	785	341,00 €	414,00 €	438,00 €
	ARTEV 5018 B	35,5	13545	9100	6480	4930	1x500	6450	12x450	12x450	2x450	1175	450	785	444,00 €	541,00 €	566,00 €
	ARTEV 5028 A	53,2	22205	15235	11860	9485	2x500	13700	10x850	10x850	2x850	1975	375	785	611,00 €	733,00 €	769,00 €
	ARTEV 5028 B	70,9	27350	19445	14375	11610	2x500	12700	12x850	12x850	2x850	1975	450	785	809,00 €	955,00 €	991,00 €
	ARTEV 5038 A	79,8	33365	22890	17825	14270	3x500	20550	10x1250	10x1250	2x1250	2775	375	815	901,00 €	1.062,00 €	1.111,00 €
	ARTEV 5038 B	106,4	39525	28275	20225	16310	3x500	19200	12x1250	12x1250	2x1250	2775	450	815	1.121,00 €	1.315,00 €	1.363,00 €
	ARTEV 5048 A	106,4	42705	29905	23615	19250	4x500	27500	10x1650	10x1650	2x1650	3575	375	815	812,00 €	1.399,00 €	1.460,00 €
	ARTEV 5048 B	141,9	53925	38450	27860	22555	4x500	25450	13x1650	13x1650	2x1650	3575	450	815	1.484,00 €	1.747,00 €	1.808,00 €

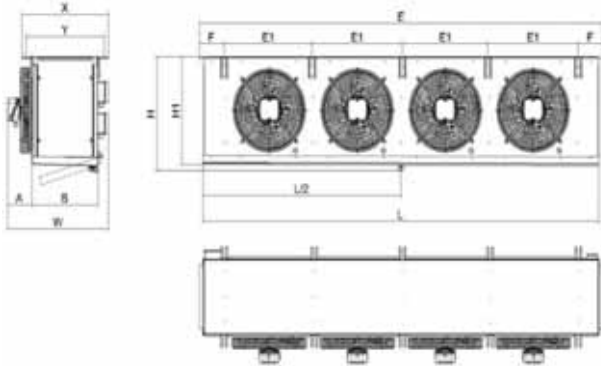

### 10 ARTEV SOĞUK ODA EVAPORATÖRLERİ 10 ARTEV COLD ROOM EVAPORATOR

Lamel Aralığı Fin Spacing	MODEL MODEL	Isı Transfer Alanı Heat Transfer Area	Kapasite Capacity (R 404 A)				Fan Çapı Fan Diameter	Hava Debisi Air Flow Rate	Defrost Isıtıcı Heater			Boyutlar Dimension			Fiyat Price		
			Watt						Batarya coil	Batarya coil	Tava Drainer				Rezistansız Without Resistance	E1 Rezistanslı With E1 Resistance	E2 Rezistanslı With E2 Resistance
			SC1	SC2	SC3	SC4						L	B	H1			
			m <sup>2</sup>	Te=0 °C	To=+10 °C	Te=-8 °C			To=0 °C	Te=-25 °C	To=-18 °C	Te=-31 °C	To=-25 °C	mm	mm	mm	€

#### 4035-1/2"

10 mm Fin Spacing	Model	Isı Transfer Alanı (m <sup>2</sup> )	Te=0 °C	To=+10 °C	Te=-8 °C	To=0 °C	Te=-25 °C	To=-18 °C	Te=-31 °C	To=-25 °C	Fan Çapı (mm)	Hava Debisi (m <sup>3</sup> /h)	Batarya coil (Watt)	Batarya coil (Watt)	Tava Drainer (Watt)	L (mm)	B (mm)	H1 (mm)	Rezistansız (€)	E1 Rezistanslı (€)	E2 Rezistanslı (€)
ARTEV 4011 A	10,1	-	-	2290	1775	1x400	4075	6x350	6x350	2x350	1025	360	705	209,00 €	253,00 €	267,00 €					
ARTEV 4011 B	15,1	-	-	3180	2300	1x400	3875	8x350	8x350	2x350	1025	360	705	267,00 €	325,00 €	340,00 €					
ARTEV 4021 A	20,2	-	-	4460	3560	2x400	8250	6x700	6x700	2x700	1675	360	705	340,00 €	404,00 €	425,00 €					
ARTEV 4021 B	30,3	-	-	5950	4620	2x400	7500	8x700	8x700	2x700	1675	360	705	454,00 €	539,00 €	560,00 €					
ARTEV 4031A	30,3	-	-	7155	5410	3x400	12375	6x1000	6x1000	2x1000	2325	360	735	486,00 €	570,00 €	598,00 €					
ARTEV 4031 B	45,4	-	-	9650	7490	3x400	11600	8x1000	8x1000	2x1000	2325	360	735	676,00 €	787,00 €	815,00 €					
ARTEV 4041 A	37,2	-	-	9020	7783	4x400	16200	6x1250	6x1250	2x1250	2775	360	735	627,00 €	724,00 €	756,00 €					
ARTEV 4041 B	55,9	-	-	12300	10731	4x400	15100	8x1250	8x1250	2x1250	2775	360	735	803,00 €	933,00 €	965,00 €					

10 mm Fin Spacing	Model	Isı Transfer Alanı (m <sup>2</sup> )	Te=0 °C	To=+10 °C	Te=-8 °C	To=0 °C	Te=-25 °C	To=-18 °C	Te=-31 °C	To=-25 °C	Fan Çapı (mm)	Hava Debisi (m <sup>3</sup> /h)	Batarya coil (Watt)	Batarya coil (Watt)	Tava Drainer (Watt)	L (mm)	B (mm)	H1 (mm)	Rezistansız (€)	E1 Rezistanslı (€)	E2 Rezistanslı (€)
ARTEV 4511 A	15,1	-	-	3510	2590	1x450	4400	8x350	8x350	2x350	1025	360	705	262,00 €	320,00 €	335,00 €					
ARTEV 4511 B	20,2	-	-	4120	3120	1x450	4110	10x350	10x350	2x350	1025	440	705	329,00 €	402,00 €	416,00 €					
ARTEV 4521 A	30,3	-	-	6850	5120	2x450	8825	8x700	8x700	2x700	1675	360	705	459,00 €	544,00 €	565,00 €					
ARTEV 4521 B	40,3	-	-	8380	6500	2x450	8225	10x700	10x700	2x700	1675	440	705	569,00 €	676,00 €	697,00 €					
ARTEV 4531 A	45,4	-	-	10750	8280	3x450	13250	9x1000	9x1000	2x1000	2325	360	735	676,00 €	801,00 €	829,00 €					
ARTEV 4531 B	60,5	-	-	13120	9880	3x450	12475	9x1000	9x1000	2x1000	2325	440	735	838,00 €	963,00 €	991,00 €					
ARTEV 4541 A	55,9	-	-	13350	11377	4x450	17250	8x1250	8x1250	2x1250	2775	360	735	803,00 €	933,00 €	965,00 €					
ARTEV 4541 B	74,5	-	-	15600	12480	4x450	16100	10x1250	10x1250	2x1250	2775	440	735	1.002,00 €	1.163,00 €	1.196,00 €					

10 mm Fin Spacing	Model	Isı Transfer Alanı (m <sup>2</sup> )	Te=0 °C	To=+10 °C	Te=-8 °C	To=0 °C	Te=-25 °C	To=-18 °C	Te=-31 °C	To=-25 °C	Fan Çapı (mm)	Hava Debisi (m <sup>3</sup> /h)	Batarya coil (Watt)	Batarya coil (Watt)	Tava Drainer (Watt)	L (mm)	B (mm)	H1 (mm)	Rezistansız (€)	E1 Rezistanslı (€)	E2 Rezistanslı (€)
ARTEV 5011 A	21,3	-	-	5180	3930	1x500	6900	9x450	9x450	2x450	1175	375	785	337,00 €	410,00 €	434,00 €					
ARTEV 5011 B	28,4	-	-	6350	4820	1x500	6350	12x450	12x450	2x450	1175	450	785	439,00 €	536,00 €	560,00 €					
ARTEV 5021 A	42,6	-	-	10910	8110	2x500	13925	10x850	10x850	2x850	1975	375	785	603,00 €	725,00 €	761,00 €					
ARTEV 5021 B	56,8	-	-	13010	9750	2x500	12800	12x850	12x850	2x850	1975	450	785	752,00 €	898,00 €	935,00 €					
ARTEV 5031 A	63,8	-	-	15910	12170	3x500	20950	10x1250	10x1250	2x1250	2775	375	815	889,00 €	1.051,00 €	1.099,00 €					
ARTEV 5031 B	85,1	-	-	18700	14320	3x500	19275	12x1250	12x1250	2x1250	2775	450	815	1.105,00 €	1.299,00 €	1.348,00 €					
ARTEV 5041 A	85,1	-	-	21780	16370	4x500	28000	10x1650	10x1650	2x1650	3575	375	815	1.285,00 €	1.507,00 €	1.574,00 €					
ARTEV 5041 B	113,5	-	-	26100	19850	4x500	25775	13x1650	13x1650	2x1650	3575	450	815	1.600,00 €	1.889,00 €	1.956,00 €					

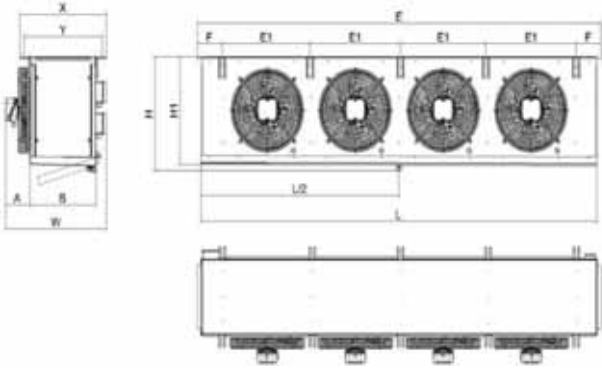

### 6 ARAS SOĞUK ODA EVAPORATÖRLERİ 6 ARAS COLD ROOM EVAPORATOR

Lamel Aralığı Fin Spacing	MODEL MODEL	Isı Transfer Alanı Heat Transfer Area	Kapasite Capacity (R 404 A)				Fan Çapı Fan Diameter	Hava Debisi Air Flow Rate	Defrost Isıtıcı Heater			Boyutlar Dimension			Fiyat Price		
			Watt						Batarya coil	Batarya coil	Tava Drainer				Rezistansız Without Resistance	E1 Rezistanslı With E1 Resistance	E2 Rezistanslı With E2 Resistance
			SC1	SC2	SC3	SC4						L	B	H1			
			m <sup>2</sup>	Te=0 °C	To=+10 °C	Te=-8 °C			To=0 °C	Te=-25 °C	To=-18 °C	Te=-31 °C	To=-25 °C	mm	mm	mm	€
<b>5648-5/8"</b>																	
6 mm Fin Spacing	ARAS 3016 A	5,9	1300	995	925	780	1x300	1550	3x250	3x250	2x250	660	360	375	169,00 €	188,00 €	200,00 €
	ARAS 3016 B	7,8	1800	1385	1275	1070	1x300	1400	4x250	4x250	2x250	660	360	375	190,00 €	215,00 €	227,00 €
	ARAS 3026 A	11,7	3200	2462	2120	1740	2x300	3100	4x450	4x450	2x450	1.060	360	375	236,00 €	269,00 €	285,00 €
	ARAS 3026 B	15,6	4500	3462	2585	2050	2x300	3300	5x450	5x450	2x450	1060	360	375	264,00 €	305,00 €	321,00 €
	ARAS 3036 A	19,6	8000	6154	5714	4848	3x300	5000	4x650	4x650	2x650	1500	360	375	314,00 €	357,00 €	379,00 €
	ARAS 3036 B	26,1	10000	7692	7143	6061	3x300	4700	5x650	5x650	2x650	1500	360	375	355,00 €	409,00 €	430,00 €
6 mm Fin Spacing	ARAS 3516 A	13,3	3450	2556	2195	1790	1x350	2550	5x250	5x250	2x250	760	400	495	239,00 €	273,00 €	287,00 €
	ARAS 3516 B	16,7	3800	2815	2300	1850	1x350	2450	7x250	7x250	2x250	760	400	495	265,00 €	313,00 €	326,00 €
	ARAS 3526 A	27,2	7400	5481	4500	3720	2x350	5000	5x500	5x500	2x500	1240	400	495	355,00 €	402,00 €	420,00 €
	ARAS 3526 B	34,0	8350	6185	5300	4425	2x350	4650	6x500	6x500	2x500	1240	400	495	393,00 €	449,00 €	468,00 €
	ARAS 3536 A	39,4	11400	8444	7200	6050	3x350	7575	5x750	5x750	2x750	1660	400	495	459,00 €	517,00 €	540,00 €
	ARAS 3536 B	49,3	12600	9333	8000	6650	3x350	7400	7x750	7x750	2x750	1660	400	495	517,00 €	599,00 €	622,00 €
6 mm Fin Spacing	ARAS 4016 A	17,4	4000	3010	2400	1920	1x400	2650	5x350	5x350	2x350	940	400	600	276,00 €	315,00 €	330,00 €
	ARAS 4016 B	23,2	5000	3900	3500	2900	1x400	3400	7x350	7x350	2x350	940	400	600	312,00 €	370,00 €	385,00 €
	ARAS 4026 A	32,6	8100	6250	5450	4520	2x400	6850	5x700	5x700	2x700	1500	400	600	411,00 €	465,00 €	486,00 €
	ARAS 4026 B	43,5	10600	7900	6850	5730	2x400	6600	7x700	7x700	2x700	1500	400	600	471,00 €	547,00 €	568,00 €
	ARAS 4036 A	48,9	11500	8600	7300	6100	3x400	11000	6x1000	6x1000	2x1000	2100	400	600	545,00 €	629,00 €	657,00 €
	ARAS 4036 B	65,2	16500	12100	10100	8500	3x400	10000	8x1000	8x1000	2x1000	2100	400	600	637,00 €	749,00 €	777,00 €
	ARAS 4046 A	54,3	15000	10750	8950	7300	4x400	14500	6x1250	6x1250	2x1250	2300	400	600	611,00 €	702,00 €	732,00 €
	ARAS 4046 B	72,4	20000	14700	12150	9975	4x400	13500	7x1250	7x1250	2x1250	2300	400	600	712,00 €	818,00 €	848,00 €
6 mm Fin Spacing	ARAS 4516 A	20,9	5250	3980	3450	2875	1x450	4350	8x350	8x350	2x350	940	400	710	309,00 €	371,00 €	387,00 €
	ARAS 4516 B	27,8	6500	4900	4200	3450	1x450	4250	9x350	9x350	2x350	940	400	710	355,00 €	425,00 €	441,00 €
	ARAS 4526 A	39,1	11500	8600	7300	6100	2x450	9000	7x700	7x700	2x700	1500	400	710	457,00 €	533,00 €	555,00 €
	ARAS 4526 B	52,1	13500	9900	8350	6900	2x450	8700	9x700	9x700	2x700	1500	400	710	535,00 €	633,00 €	654,00 €
	ARAS 4536 A	58,7	15000	11000	9350	7900	3x450	12350	8x1000	8x1000	2x1000	2100	400	710	618,00 €	730,00 €	758,00 €
	ARAS 4536 B	78,2	19500	14300	12100	10000	3x450	11850	9x1000	9x1000	2x1000	2100	400	710	727,00 €	853,00 €	881,00 €
	ARAS 4546 A	71,7	23250	16800	13500	11150	4x450	18500	8x1250	8x1250	2x1250	2500	400	710	742,00 €	872,00 €	904,00 €
	ARAS 4546 B	95,6	26500	19200	15600	12700	4x450	17500	10x1250	10x1250	2x1250	2500	400	710	887,00 €	1.049,00 €	1.082,00 €
6 mm Fin Spacing	ARAS 5016 A	32,4	8000	6200	5300	4400	1x500	6600	9x450	9x450	2x450	940	450	820	412,00 €	483,00 €	506,00 €
	ARAS 5016 B	40,6	9800	7400	6350	5200	1x500	6000	11x450	11x450	2x450	940	450	820	465,00 €	551,00 €	575,00 €
	ARAS 5026 A	60,8	16500	12100	10100	8500	2x500	13000	10x850	10x850	2x850	1500	450	820	622,00 €	731,00 €	763,00 €
	ARAS 5026 B	76,0	20400	15000	12650	10450	2x500	12000	12x850	12x850	2x850	1500	450	820	712,00 €	842,00 €	875,00 €
	ARAS 5036 A	91,3	24500	17750	13450	11100	3x500	18250	10x1250	10x1250	2x1250	2100	450	820	849,00 €	989,00 €	1.031,00 €
	ARAS 5036 B	114,1	31000	22350	16950	13575	3x500	17100	12x1250	12x1250	2x1250	2100	450	820	999,00 €	1.167,00 €	1.210,00 €
	ARAS 5046 A	121,7	35000	25100	18500	14600	4x500	24250	10x1650	10x1650	2x1650	2700	450	820	1.077,00 €	1.250,00 €	1.302,00 €
	ARAS 5046 B	152,1	38000	27100	21000	16650	4x500	21000	12x1650	12x1650	2x1650	2700	450	820	1.242,00 €	1.449,00 €	1.501,00 €

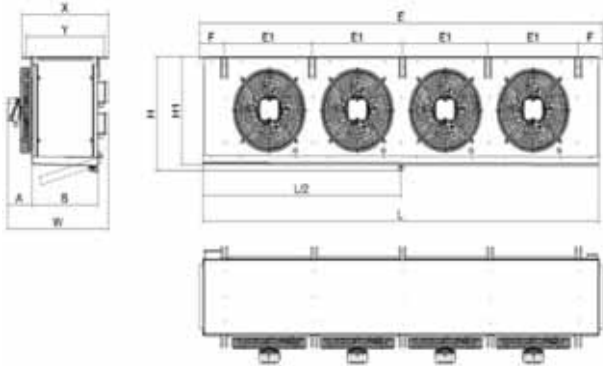

### 8 ARAS SOĞUK ODA EVAPORATÖRLERİ 8 ARAS COLD ROOM EVAPORATOR

Lamel Aralığı Fin Spacing	MODEL MODEL	Isı Transfer Alanı Heat Transfer Area	Kapasite Capacity (R 404 A)				Fan Çapı Fan Diameter	Hava Debisi Air Flow Rate	Defrost Isıtıcı Heater			Boyutlar Dimension			Fiyat Price		
			Watt						Batarya coil	Batarya coil	Tava Drainer				Rezistansız Without Resistance	E1 Rezistanslı With E1 Resistance	E2 Rezistanslı With E2 Resistance
			SC1	SC2	SC3	SC4						L	B	H1			
			m <sup>2</sup>	Te=0 °C To=+10 °C	Te=-8 °C To=0 °C	Te=-25 °C To=-18 °C			Te=-31 °C To=-25 °C	mm	m <sup>3</sup> /h	Watt	Watt	Watt	mm	mm	mm

#### 5648-5/8"

8 mm Fin Spacing	ARAS 3018 A	4,4	1300	995	925	780	1x300	1550	3x250	3x250	2x250	660	360	375	168,00 €	187,00 €	199,00 €
	ARAS 3018 B	5,9	1800	1385	1275	1070	1x300	1400	4x250	4x250	2x250	660	360	375	186,00 €	211,00 €	223,00 €
	ARAS 3028 A	8,8	3200	2462	2120	1740	2x300	3100	4x450	4x450	2x450	1060	360	375	233,00 €	266,00 €	282,00 €
	ARAS 3028 B	11,7	4500	3462	2585	2050	2x300	3300	5x450	5x450	2x450	1060	360	375	260,00 €	301,00 €	317,00 €
	ARAS 3038 A	14,7	8000	6154	5714	4848	3x300	5000	4x650	4x650	2x650	1500	360	375	309,00 €	352,00 €	373,00 €
	ARAS 3038 B	19,6	10000	7692	7143	6061	3x300	4700	5x650	5x650	2x650	1500	360	375	348,00 €	402,00 €	423,00 €
8 mm Fin Spacing	ARAS 3518 A	10,0	3450	2556	2195	1790	1x350	2550	5x250	5x250	2x250	760	400	495	236,00 €	270,00 €	283,00 €
	ARAS 3518 B	12,5	3800	2815	2300	1850	1x350	2450	7x250	7x250	2x250	760	400	495	261,00 €	308,00 €	322,00 €
	ARAS 3528 A	20,4	7400	5481	4500	3720	2x350	5000	5x500	5x500	2x500	1240	400	495	348,00 €	394,00 €	413,00 €
	ARAS 3528 B	25,5	8350	6185	5300	4425	2x350	4650	6x500	6x500	2x500	1240	400	495	389,00 €	445,00 €	464,00 €
	ARAS 3538 A	29,6	11400	8444	7200	6050	3x350	7575	5x750	5x750	2x750	1660	400	495	448,00 €	506,00 €	530,00 €
	ARAS 3538 B	36,9	12600	9333	8000	6650	3x350	7400	7x750	7x750	2x750	1660	400	495	504,00 €	585,00 €	609,00 €
8 mm Fin Spacing	ARAS 4018 A	13,0	4000	3010	2400	1920	1x400	2650	6x350	6x350	2x350	940	400	600	271,00 €	318,00 €	333,00 €
	ARAS 4018 B	17,4	5000	3900	3500	2900	1x400	3400	8x350	8x350	2x350	940	400	600	309,00 €	371,00 €	387,00 €
	ARAS 4028 A	24,4	8100	6250	5450	4520	2x400	6850	6x700	6x700	2x700	1500	400	600	397,00 €	461,00 €	483,00 €
	ARAS 4028 B	32,6	10600	7900	6850	5730	2x400	6600	7x700	7x700	2x700	1500	400	600	460,00 €	535,00 €	557,00 €
	ARAS 4038 A	36,7	11500	8600	7300	6100	3x400	11000	6x1000	6x1000	2x1000	2100	400	600	531,00 €	616,00 €	644,00 €
	ARAS 4038 B	48,9	16500	12100	10100	8500	3x400	10000	8x1000	8x1000	2x1000	2100	400	600	619,00 €	731,00 €	759,00 €
	ARAS 4048 A	40,7	15000	10750	8950	7300	4x400	14500	6x1250	6x1250	2x1250	2300	400	600	596,00 €	687,00 €	717,00 €
	ARAS 4048 B	54,3	20000	14700	12150	9975	4x400	13500	8x1250	8x1250	2x1250	2300	400	600	693,00 €	813,00 €	844,00 €
8 mm Fin Spacing	ARAS 4518 A	15,6	5250	3980	3450	2875	1x450	4350	8x350	8x350	2x350	940	400	710	303,00 €	365,00 €	381,00 €
	ARAS 4518 B	20,9	6500	4900	4200	3450	1x450	4250	10x350	10x350	2x350	940	400	710	347,00 €	425,00 €	441,00 €
	ARAS 4528 A	29,3	11500	8600	7300	6100	2x450	9000	8x700	8x700	2x700	1500	400	710	447,00 €	533,00 €	555,00 €
	ARAS 4528 B	39,1	13500	9900	8350	6900	2x450	8700	10x700	10x700	2x700	1500	400	710	521,00 €	629,00 €	651,00 €
	ARAS 4538 A	44,0	15000	11000	9350	7900	3x450	12350	9x1000	9x1000	2x1000	2100	400	710	602,00 €	728,00 €	756,00 €
	ARAS 4538 B	58,7	19500	14300	12100	10000	3x450	11850	9x1000	9x1000	2x1000	2100	400	710	705,00 €	832,00 €	860,00 €
	ARAS 4548 A	53,8	23250	16800	13500	11150	4x450	18500	8x1250	8x1250	2x1250	2500	400	710	723,00 €	852,00 €	885,00 €
	ARAS 4548 B	71,7	26500	19200	15600	12700	4x450	17500	10x1250	10x1250	2x1250	2500	400	710	841,00 €	1.003,00 €	1.036,00 €
8 mm Fin Spacing	ARAS 5018 A	24,3	8000	6200	5300	4400	1x500	6600	9x450	9x450	2x450	940	450	820	403,00 €	474,00 €	497,00 €
	ARAS 5018 B	30,4	9800	7400	6350	5200	1x500	6000	12x450	12x450	2x450	940	450	820	454,00 €	548,00 €	571,00 €
	ARAS 5028 A	45,6	16500	12100	10100	8500	2x500	13000	10x850	10x850	2x850	1500	450	820	606,00 €	714,00 €	747,00 €
	ARAS 5028 B	57,0	20400	15000	12650	10450	2x500	12000	12x850	12x850	2x850	1500	450	820	692,00 €	822,00 €	854,00 €
	ARAS 5038 A	68,4	24500	17750	13450	11100	3x500	18250	10x1250	10x1250	2x1250	2100	450	820	824,00 €	964,00 €	1.006,00 €
	ARAS 5038 B	85,6	31000	22350	16950	13575	3x500	17100	12x1250	12x1250	2x1250	2100	450	820	944,00 €	1.112,00 €	1.155,00 €
	ARAS 5048 A	91,3	35000	25100	18500	14600	4x500	24250	10x1650	10x1650	2x1650	2700	450	820	1.044,00 €	1.217,00 €	1.269,00 €
	ARAS 5048 B	114,1	38000	27100	21000	16650	4x500	21000	13x1650	13x1650	2x1650	2700	450	820	1.200,00 €	1.425,00 €	1.477,00 €

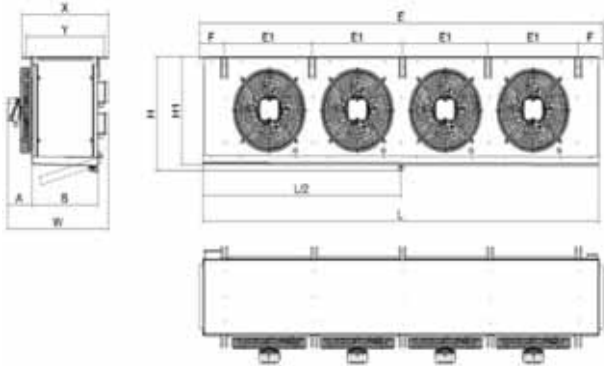

### 10 ARAS SOĞUK ODA EVAPORATÖRLERİ 10 ARAS COLD ROOM EVAPORATOR

Lamel Aralığı Fin Spacing	MODEL MODEL	Isı Transfer Alanı Heat Transfer Area	Kapasite Capacity (R 404 A)				Fan Çapı Fan Diameter	Hava Debişi Air Flow Rate	Defrost Isıtıcı Defrost Heater			Boyutlar Dimension			Fiyat Price		
			Watt						Batarya coil	Batarya coil	Tava Drainer				Rezistansız Without Resistance	E1 Rezistanslı With E1 Resistance	E2 Rezistanslı With E2 Resistance
			SC1	SC2	SC3	SC4						L	B	H1			
			m <sup>2</sup>	Te=0 °C To=+10 °C	Te=-8 °C To=0 °C	Te=-25 °C To=-18 °C			Te=-31 °C To=-25 °C	mm	m <sup>3</sup> /h	Waat	Waat	Waat	mm	mm	mm
<b>5648-5/8"</b>																	
10 mm Fin Spacing	ARAS 4011 A	10,4	4000	3010	2400	1920	1x400	2650	6x350	6x350	2x350	940	400	600	265,00 €	312,00 €	328,00 €
	ARAS 4011 B	13,9	5000	3900	3500	2900	1x400	3400	8x350	8x350	2x350	940	400	600	298,00 €	360,00 €	375,00 €
	ARAS 4021 A	19,6	8100	6250	5450	4520	2x400	6850	6x700	6x700	2x700	1500	400	600	366,00 €	431,00 €	453,00 €
	ARAS 4021 B	26,1	10600	7900	6850	5730	2x400	6600	7x700	7x700	2x700	1500	400	600	428,00 €	504,00 €	525,00 €
	ARAS 4031 A	29,3	11500	8600	7300	6100	3x400	11000	6x1000	6x1000	2x1000	2100	400	600	501,00 €	585,00 €	613,00 €
	ARAS 4031 B	39,1	16500	12100	10100	8500	3x400	10000	8x1000	8x1000	2x1000	2100	400	600	619,00 €	731,00 €	759,00 €
	ARAS 4041 A	32,6	15000	10750	8950	7300	4x400	14500	6x1250	6x1250	2x1250	2300	400	600	603,00 €	693,00 €	723,00 €
ARAS 4041 B	43,5	20000	14700	12150	9975	4x400	13500	8x1250	8x1250	2x1250	2300	400	600	693,00 €	814,00 €	844,00 €	
10 mm Fin Spacing	ARAS 4511 A	12,5	5250	3980	3450	2875	1x450	4350	8x350	8x350	2x350	940	400	710	297,00 €	359,00 €	375,00 €
	ARAS 4511 B	16,7	6500	4900	4200	3450	1x450	4250	10x350	10x350	2x350	940	400	710	336,00 €	414,00 €	429,00 €
	ARAS 4521 A	23,5	11500	8600	7300	6100	2x450	9000	8x700	8x700	2x700	1500	400	710	441,00 €	527,00 €	549,00 €
	ARAS 4521 B	31,3	13500	9900	8350	6900	2x450	8700	10x700	10x700	2x700	1500	400	710	510,00 €	618,00 €	639,00 €
	ARAS 4531 A	35,2	15000	11000	9350	7900	3x450	12350	9x1000	9x1000	2x1000	2100	400	710	607,00 €	734,00 €	762,00 €
	ARAS 4531 B	46,9	19500	14300	12100	10000	3x450	11850	9x1000	9x1000	2x1000	2100	400	710	706,00 €	832,00 €	860,00 €
	ARAS 4541 A	43,0	23250	16800	13500	11150	4x450	18500	8x1250	8x1250	2x1250	2500	400	710	723,00 €	852,00 €	885,00 €
ARAS 4541 B	57,4	26500	19200	15600	12700	4x450	17500	10x1250	10x1250	2x1250	2500	400	710	841,00 €	1.003,00 €	1.036,00 €	
10 mm Fin Spacing	ARAS 5011 A	19,5	8000	6200	5300	4400	1x500	6600	9x450	9x450	2x450	940	450	820	392,00 €	462,00 €	486,00 €
	ARAS 5011 B	24,3	9800	7400	6350	5200	1x500	6000	12x450	12x450	2x450	940	450	820	454,00 €	548,00 €	572,00 €
	ARAS 5021 A	36,5	16500	12100	10100	8500	2x500	13000	10x850	10x850	2x850	1500	450	820	606,00 €	714,00 €	747,00 €
	ARAS 5021 B	45,6	20400	15000	12650	10450	2x500	12000	12x850	12x850	2x850	1500	450	820	692,00 €	822,00 €	854,00 €
	ARAS 5031 A	54,8	24500	17750	13450	11100	3x500	18250	10x1250	10x1250	2x1250	2100	450	820	824,00 €	965,00 €	1.007,00 €
	ARAS 5031 B	68,4	31000	22350	16950	13575	3x500	17100	12x1250	12x1250	2x1250	2100	450	820	944,00 €	1.113,00 €	1.155,00 €
	ARAS 5041 A	73,0	35000	25100	18500	14600	4x500	24250	10x1650	10x1650	2x1650	2700	450	820	1.044,00 €	1.218,00 €	1.269,00 €
ARAS 5041 B	91,3	38000	27100	21000	16650	4x500	21000	13x1650	13x1650	2x1650	2700	450	820	1.201,00 €	1.425,00 €	1.477,00 €	

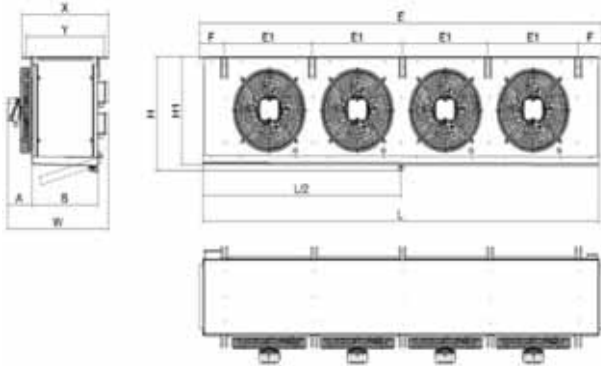

### 6 AREV SOĞUK ODA EVAPORATÖRLERİ 6 AREV COLD ROOM EVAPORATOR

Lamel Analığı Fin Spacing	MODEL MODEL	Isı Transfer Alanı Heat Transfer Area	Kapasite Capacity (R 404 A)				Fan Çapı Fan Diameter	Hava Debisi Air Flow Rate	Defrost Isıtıcı Heater			Boyutlar Dimension			Fiyat Price		
			Watt						Batarya coil	Batarya coil	Tava Drainer				Rezistansız Without Resistance	E1 Rezistanslı With E1 Resistance	E2 Rezistanslı With E2 Resistance
			SC1	SC2	SC3	SC4						L	B	H1			
			m <sup>2</sup>	Te=0 °C	To=+10 °C	Te=-8 °C			To=0 °C	Te=-25 °C	To=-18 °C	Te=-31 °C	To=-25 °C	mm	mm	mm	€
<b>3228-3/8"</b>																	
6 mm Fin Spacing	AREV 3016 A	5,7	2605	1760	1300	1000	1x300	1750	3x250	3x250	2x250	700	290	490	133,00 €	151,00 €	163,00 €
	AREV 3016 B	8,5	3520	2300	1740	1350	1x300	1550	4x250	4x250	2x250	700	290	490	154,00 €	178,00 €	190,00 €
	AREV 3026 A	11,4	5490	3775	2790	2130	2x300	3500	4x450	4x450	2x450	1100	290	490	206,00 €	238,00 €	254,00 €
	AREV 3026 B	17,0	7350	5050	3750	2850	2x300	3100	5x450	5x450	2x450	1100	290	490	250,00 €	290,00 €	306,00 €
	AREV 3036 A	17,0	8300	5750	4240	3260	3x300	5150	4x650	4x650	2x650	1500	290	490	271,00 €	312,00 €	332,00 €
	AREV 3036 B	25,5	11120	7520	5700	4380	3x300	4700	5x650	5x650	2x650	1500	290	490	332,00 €	382,00 €	402,00 €
6 mm Fin Spacing	AREV 3516 A	8,9	3920	2690	2050	1570	1x350	2600	5x250	5x250	2x250	800	290	585	164,00 €	197,00 €	210,00 €
	AREV 3516 B	13,3	5485	3775	2745	2100	1x350	2400	7x250	7x250	2x250	800	290	585	196,00 €	241,00 €	254,00 €
	AREV 3526 A	17,7	8300	5750	4280	3300	2x350	4950	5x500	5x500	2x500	1300	290	585	263,00 €	308,00 €	326,00 €
	AREV 3526 B	26,6	10700	7030	5420	4240	2x350	4750	6x500	6x500	2x500	1300	290	585	326,00 €	381,00 €	399,00 €
	AREV 3536 A	26,6	12510	8670	6390	4925	3x350	7250	5x750	5x750	2x750	1800	290	585	359,00 €	417,00 €	440,00 €
	AREV 3536 B	39,9	16760	11540	8600	6615	3x350	6850	7x750	7x750	2x750	1800	290	585	440,00 €	522,00 €	545,00 €
<b>3228-1/2"</b>																	
6 mm Fin Spacing	AREV 4016 A	12,3	5920	3795	2903	2356	1x400	3750	5x250	5x250	2x350	1045	580	705	291,00 €	327,00 €	342,00 €
	AREV 4016 B	18,4	8226	5393	4025	3316	1x400	3450	7x350	7x350	2x350	1045	580	705	349,00 €	400,00 €	415,00 €
	AREV 4026 A	24,6	12461	8254	5798	4783	2x400	7400	5x700	5x700	2x700	1695	580	705	456,00 €	509,00 €	530,00 €
	AREV 4026 B	36,9	16323	10699	8015	6627	2x400	6700	7x700	7x700	2x700	1695	580	705	584,00 €	658,00 €	679,00 €
	AREV 4036 A	36,9	18945	12375	9301	7745	3x400	11075	6x1000	6x1000	2x1000	2345	580	705	645,00 €	729,00 €	756,00 €
	AREV 4036 B	55,3	24003	15570	11690	9600	3x400	10400	8x1000	8x1000	2x1000	2345	580	705	853,00 €	964,00 €	992,00 €
	AREV 4046 A	45,4	21960	13507	10675	8686	4x400	14450	6x1250	6x1250	2x1250	2795	580	705	817,00 €	914,00 €	946,00 €
	AREV 4046 B	68,1	31411	20501	15627	12880	4x400	13450	7x1250	7x1250	2x1250	2795	580	705	1.012,00 €	1.125,00 €	1.157,00 €
6 mm Fin Spacing	AREV 4516 A	20,7	9219	6146	4164	3364	1x450	4150	8x350	8x350	2x350	1045	550	735	370,00 €	429,00 €	443,00 €
	AREV 4516 B	27,7	11302	7432	5521	4508	1x450	3900	9x350	9x350	2x350	1045	630	735	462,00 €	528,00 €	542,00 €
	AREV 4526 A	41,5	18655	12430	8513	7046	2x450	8100	7x700	7x700	2x700	1695	550	735	619,00 €	693,00 €	714,00 €
	AREV 4526 B	55,3	20098	13535	8715	9178	2x450	7400	9x700	9x700	2x700	1695	630	735	759,00 €	854,00 €	876,00 €
	AREV 4536 A	62,2	28426	18938	13012	10770	3x450	12350	8x1000	8x1000	2x1000	2345	550	735	885,00 €	996,00 €	1.024,00 €
	AREV 4536 B	83,0	33679	22475	15509	12774	3x450	11550	9x1000	9x1000	2x1000	2345	630	735	1.101,00 €	1.226,00 €	1.254,00 €
	AREV 4546 A	76,6	36465	24214	16960	13901	4x450	16000	8x1250	7x1250	2x1250	2795	550	735	1.068,00 €	1.182,00 €	1.214,00 €
	AREV 4546 B	102,2	40281	27059	17803	15336	4x450	14750	10x1250	10x1250	2x1250	2795	630	735	1.313,00 €	1.475,00 €	1.507,00 €
6 mm Fin Spacing	AREV 5016 A	28,4	14303	9373	6960	5772	1x500	6650	9x450	9x450	2x450	1195	575	815	479,00 €	552,00 €	576,00 €
	AREV 5016 B	37,8	17303	11367	8464	7020	1x500	6100	11x450	11x450	2x450	1195	655	815	591,00 €	680,00 €	704,00 €
	AREV 5026 A	56,8	29332	19244	14273	11869	2x500	13300	10x850	10x850	2x850	1995	575	815	840,00 €	962,00 €	998,00 €
	AREV 5026 B	75,7	33704	22145	16530	13740	2x500	12150	12x850	12x850	2x850	1995	655	815	1.048,00 €	1.194,00 €	1.231,00 €
	AREV 5036 A	85,1	42972	28000	21471	17866	3x500	19900	10x1250	10x1250	2x1250	2795	575	815	1.203,00 €	1.365,00 €	1.414,00 €
	AREV 5036 B	113,5	49117	3126	21505	16691	3x500	18250	12x1250	12x1250	2x1250	2795	655	815	1.477,00 €	1.672,00 €	1.720,00 €
	AREV 5046 A	113,5	55926	35397	25210	19276	4x500	26450	10x1650	10x1650	2x1650	3595	575	815	1.520,00 €	1.722,00 €	1.783,00 €
	AREV 5046 B	151,3	60950	42240	31910	23985	4x500	24250	12x1650	12x1650	2x1650	3595	655	815	1.873,00 €	2.115,00 €	2.176,00 €

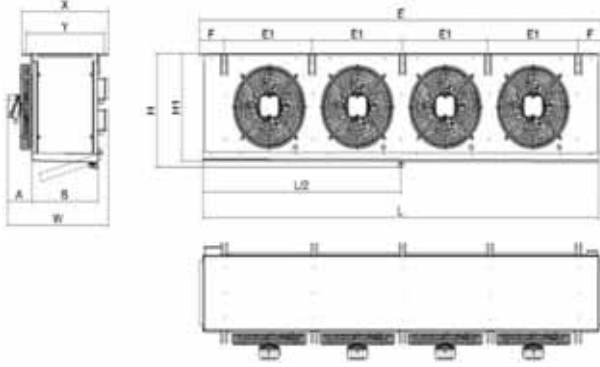

### 8 AREV SOĞUK ODA EVAPORATÖRLERİ 8 AREV COLD ROOM EVAPORATOR

Lamel Aralığı Fin Spacing	MODEL MODEL	Isı Transfer Alanı Heat Transfer Area	Kapasite Capacity (R 404 A)				Fan Çapı Fan Diameter	Hava Debisi Air Flow Rate	Defrost Isıtıcı Heater			Boyutlar Dimension			Fiyat Price		
			Watt						E1	E2					Rezistansız Without Resistance	E1 Rezistanslı With E1 Resistance	E2 Rezistanslı With E2 Resistance
			SC1	SC2	SC3	SC4				Batarya coil	Batarya coil	Tava Drainer	L	B			
			m <sup>2</sup>	Te=0°C To=+10 °C	Te= -8 °C To=0°C	Te=-25 °C To=-18 °C			Te=-31 °C To=-25 °C	mm	m <sup>3</sup> /h	Waat	Waat	Waat	mm	mm	mm
<b>3228-3/8"</b>																	
8 mm Fin Spacing	AREV 3018 A	4,3	2150	1420	1100	860	1x300	1650	3x250	3x250	2x250	700	290	490	137,00 €	155,00 €	167,00 €
	AREV 3018 B	6,4	3015	1890	1490	1150	1x300	1525	4x250	4x250	2x250	700	290	490	167,00 €	191,00 €	203,00 €
	AREV 3028 A	8,5	4530	3185	2400	1835	2x300	3225	4x450	4x450	2x450	1100	290	490	217,00 €	249,00 €	265,00 €
	AREV 3028 B	12,8	6300	4350	3220	2500	2x300	3100	5x450	5x450	2x450	1100	290	490	264,00 €	304,00 €	320,00 €
	AREV 3038 A	12,8	6970	4800	3620	2750	3x300	5050	4x650	4x650	2x650	1500	290	490	281,00 €	326,00 €	342,00 €
	AREV 3038 B	19,2	9630	6600	4825	3770	3x300	4450	5x650	5x650	2x650	1500	290	490	345,00 €	396,00 €	416,00 €
8 mm Fin Spacing	AREV 3518 A	6,7	6,91	3340	2230	1710	1x350	2500	5x250	5x250	2x250	800	290	585	171,00 €	204,00 €	217,00 €
	AREV 3518 B	10,0	10,37	4800	3310	2410	1x350	2300	7x250	7x250	2x250	800	290	585	204,00 €	250,00 €	263,00 €
	AREV 3528 A	13,3	13,82	6950	4825	3600	2x350	4800	5x500	5x500	2x500	1300	290	585	273,00 €	318,00 €	337,00 €
	AREV 3528 B	20,0	20,74	9310	5930	4650	2x350	4700	6x500	6x500	2x500	1300	290	585	341,00 €	395,00 €	413,00 €
	AREV 3538 A	20,0	20,74	10890	7470	5440	3x350	7575	5x750	5x750	2x750	1800	290	585	373,00 €	431,00 €	455,00 €
	AREV 3538 B	29,9	31,10	14750	10140	7545	3x350	7250	7x750	7x750	2x750	1800	290	585	474,00 €	555,00 €	578,00 €
<b>3228-1/2"</b>																	
8 mm Fin Spacing	AREV 4018 A	9,2	4985	2975	2342	1909	1x400	3700	6x350	6x350	2x350	1045	580	705	288,00 €	332,00 €	346,00 €
	AREV 4018 B	13,8	7150	4680	3484	2828	1x400	3600	8x350	8x350	2x350	1045	580	705	345,00 €	403,00 €	418,00 €
	AREV 4028 A	18,4	10883	7203	5120	4204	2x400	7500	6x700	6x700	2x700	1695	580	705	450,00 €	514,00 €	535,00 €
	AREV 4028 B	27,7	14277	6800	6974	5685	2x400	6800	8x700	8x700	2x700	1695	580	705	575,00 €	659,00 €	681,00 €
	AREV 4038 A	27,7	16265	10617	8041	6618	3x400	11200	6x1000	6x1000	2x1000	2345	580	705	636,00 €	720,00 €	747,00 €
	AREV 4038 B	41,5	20789	12879	9820	8074	3x400	10500	8x1000	8x1000	2x1000	2345	580	705	839,00 €	951,00 €	978,00 €
	AREV 4048 A	34,1	18698	10761	8700	7100	4x400	14650	6x1250	6x1250	2x1250	2795	580	705	806,00 €	903,00 €	935,00 €
	AREV 4048 B	51,1	27531	17942	13497	11032	4x400	13800	8x1250	8x1250	2x1250	2795	580	705	992,00 €	1.121,00 €	1.154,00 €
8 mm Fin Spacing	AREV 4518 A	15,6	8292	5521	3794	3084	1x450	4250	8x350	8x350	2x350	1045	550	735	365,00 €	424,00 €	438,00 €
	AREV 4518 B	20,7	10027	6579	4824	3950	1x450	3950	10x350	10x350	2x350	1045	630	735	443,00 €	517,00 €	531,00 €
	AREV 4528 A	31,1	16811	11188	7759	6348	2x450	8400	8x700	8x700	2x700	1695	550	735	614,00 €	699,00 €	721,00 €
	AREV 4528 B	41,5	18650	12540	8192	6590	2x450	7650	10x700	10x700	2x700	1695	630	735	732,00 €	838,00 €	860,00 €
	AREV 4538 A	46,7	25478	16954	11794	9667	3x450	12700	9x1000	9x1000	2x1000	2345	550	735	870,00 €	995,00 €	1.023,00 €
	AREV 4538 B	62,2	30595	20381	14215	11728	3x450	11900	9x1000	9x1000	2x1000	2345	630	735	1.081,00 €	1.206,00 €	1.234,00 €
	AREV 4548 A	57,5	32504	21560	15269	12578	4x450	16450	8x1250	8x1250	2x1250	2795	550	735	1.050,00 €	1.179,00 €	1.212,00 €
	AREV 4548 B	76,6	37215	24965	16648	13499	4x450	15350	10x1250	10x1250	2x1250	2795	630	735	1.289,00 €	1.450,00 €	1.483,00 €
8 mm Fin Spacing	AREV 5018 A	21,3	12634	8269	6215	5121	1x500	6875	9x450	9x450	2x450	1195	575	815	474,00 €	547,00 €	571,00 €
	AREV 5018 B	28,4	15212	9976	7459	6074	1x500	6450	12x450	12x450	2x450	1195	655	815	584,00 €	681,00 €	705,00 €
	AREV 5028 A	42,6	25847	16937	12704	10532	2x500	13700	10x850	10x850	2x850	1995	575	815	827,00 €	948,00 €	985,00 €
	AREV 5028 B	56,8	30342	19894	14918	12191	2x500	12700	12x850	12x850	2x850	1995	655	815	1.030,00 €	1.176,00 €	1.212,00 €
	AREV 5038 A	63,8	37721	24551	18865	15347	3x500	20550	10x1250	10x1250	2x1250	2795	575	815	1.186,00 €	1.349,00 €	1.397,00 €
	AREV 5038 B	85,1	44341	28040	18838	14559	3x500	19200	12x1250	12x1250	2x1250	2795	655	815	1.449,00 €	1.644,00 €	1.693,00 €
	AREV 5048 A	85,1	49401	31198	21449	16384	4x500	27500	10x1650	10x1650	2x1650	3595	575	815	1.530,00 €	1.732,00 €	1.793,00 €
	AREV 5048 B	113,5	54850	38020	28880	21740	4x500	25450	13x1650	13x1650	2x1650	3595	655	815	1.836,00 €	2.099,00 €	2.160,00 €



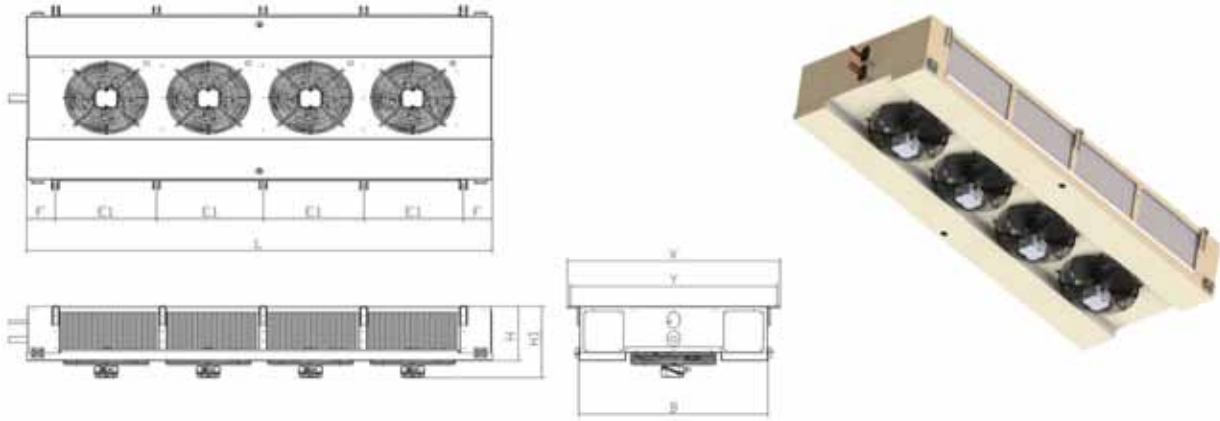

## ARTE SERİSİ ÇİFT ÜFLEMELİ TAVAN SOĞUTUCULAR ARTE SERIES DUAL DISCHARGE AIR COLLERS

Lamel Aralığı Fin Spacing	MODEL MODEL	Isı Transfer Alanı Heat Transfer Area	Kapasite Capacity (R 404 A)				Fan Fan		Defrost Isıtıcı Heater Defrost			Boyutlar Dimension			Fiyat Price				
			Watt				Fan Çapı Fan Diameter	Hava Debisi Air Flow Rate	E1		Tava Drainer	L	B	H1	Rezistansız Without Resistance	E1 Rezistanslı With E1 Resistance	E2 Rezistanslı With E2 Resistance		
			SC1	SC2	SC3	SC4			Batarya coil	Batarya coil								Watt	Watt
			m <sup>2</sup>	Te=0 °C	To=+10 °C	Te=-8 °C	To=0 °C	Te=-25 °C	To=-18 °C	Te=-31 °C	To=-25 °C	mm	m <sup>3</sup> /h	Watt	Watt	Watt	mm	mm	mm
<b>3228-3/8"</b>																			
4 mm Havne Fin Spaces	ARTE 25.14 A	6,4	1610	1055	-	-	1x250	840	2x250	-	-	700	800	240	161,00 €	174,00 €	-		
	ARTE 25.14 B	12,8	2765	1910	-	-	1x250	765	4x250	-	-	700	800	240	215,00 €	241,00 €	-		
	ARTE 25.24 A	17,0	4335	2845	-	-	2x250	1620	4x250	-	-	1100	800	240	272,00 €	306,00 €	-		
	ARTE 25.24 B	25,5	5590	3900	-	-	2x250	1510	4x450	-	-	1100	800	240	348,00 €	382,00 €	-		
	ARTE 30.14 A	12,8	4020	2870	-	-	1x300	1480	4x250	-	-	700	800	240	253,00 €	279,00 €	-		
	ARTE 30.24 A	25,5	8240	5870	-	-	2x300	2960	6x250	-	-	1100	800	240	356,00 €	407,00 €	-		
	ARTE 30.34 A	38,3	12500	8900	-	-	3x300	4450	6x650	-	-	1500	800	240	458,00 €	522,00 €	-		
<b>3228-1/2"</b>																			
4 mm Havne Fin Spaces	ARTE 40.14 A	20,8	7750	5400	-	-	1x400	3080	6x350	-	-	950	1150	300	358,00 €	405,00 €	-		
	ARTE 40.24 A	41,5	15060	10320	-	-	2x400	6160	8x700	-	-	1.600	1150	300	614,00 €	704,00 €	-		
	ARTE 40.34 A	62,2	23800	16600	-	-	3x400	9240	8x1000	-	-	2.250	1150	300	840,00 €	958,00 €	-		
	ARTE 40.44 A	76,6	29800	20650	-	-	4x400	12300	8x1250	-	-	2.700	1150	300	1.007,00 €	1.144,00 €	-		
<b>3228-3/8"</b>																			
6 mm	ARTE 25.16 A	4,3	1225	810	665	540	1x250	860	2x250	2x250	2x250	700	800	240	160,00 €	173,00 €	186,00 €		
	ARTE 25.16 B	8,5	2480	1690	1225	1225	1x250	800	4x250	4x250	2x250	700	800	240	214,00 €	240,00 €	252,00 €		
	ARTE 25.26 A	11,4	3580	2280	1790	1425	2x250	1720	4x450	4x450	2x450	1100	800	240	270,00 €	304,00 €	321,00 €		
	ARTE 25.26 B	17,1	4980	3380	2475	1960	2x250	1600	6x450	6x450	2x450	1100	800	240	345,00 €	396,00 €	413,00 €		
	ARTE 30.16 A	8,5	3530	2450	1790	1350	1x300	1540	4x250	4x250	2x250	700	800	240	252,00 €	277,00 €	290,00 €		
	ARTE 30.26 A	17,1	7190	4980	3675	2820	2x300	3080	6x450	6x450	2x450	1100	800	240	353,00 €	405,00 €	422,00 €		
	ARTE 30.36 A	25,5	10830	7500	5600	4290	3x300	4620	6x650	6x650	2x650	1500	800	240	454,00 €	518,00 €	539,00 €		
	ARTE 35.16 A	10,7	4535	3170	2230	1700	1x350	2120	6x250	6x250	2x250	800	800	240	281,00 €	322,00 €	336,00 €		
	ARTE 35.26 A	21,3	9260	6500	4650	3560	2x350	4240	6x500	6x500	2x500	1300	800	240	388,00 €	446,00 €	465,00 €		
	ARTE 35.36 A	32,0	14020	9800	7060	5450	3x350	6360	6x750	6x750	2x750	1800	800	240	519,00 €	593,00 €	618,00 €		
	ARTE 35.46 A	42,6	18800	13110	9500	7350	4x350	8480	6x1000	6x1000	2x1000	2300	800	240	656,00 €	746,00 €	776,00 €		
<b>3228-1/2"</b>																			
6 mm	ARTE 40.16 A	13,8	6950	4830	3600	2700	1x400	3250	8x350	8x350	2x350	950	1150	300	344,00 €	406,00 €	421,00 €		
	ARTE 40.26 A	27,7	12900	8560	6850	5270	2x400	6500	8x700	8x700	2x700	1600	1150	300	573,00 €	662,00 €	685,00 €		
	ARTE 40.36 A	41,5	21200	14680	11220	8410	3x400	9750	8x1000	8x1000	2x1000	2250	1150	300	794,00 €	912,00 €	942,00 €		
	ARTE 40.46 A	51,1	26500	18275	13370	10160	4x400	12500	8x1250	8x1250	2x1250	2700	1150	300	969,00 €	1.107,00 €	1.141,00 €		
	ARTE 45.16 A	18,4	8000	5050	4125	3140	1x450	3560	8x350	8x350	2x350	950	1150	380	427,00 €	489,00 €	505,00 €		
	ARTE 45.26 A	36,9	16000	10150	8200	6320	2x450	7120	8x700	8x700	2x700	1600	1150	380	687,00 €	777,00 €	800,00 €		
	ARTE 45.36 A	55,3	25650	17820	13450	10200	3x450	10680	10x1000	10x1000	2x1000	2250	1150	380	964,00 €	1.112,00 €	1.142,00 €		
	ARTE 45.46 A	68,1	31300	21450	16400	12600	4x450	13450	10x1250	10x1250	2x1250	2700	1150	380	1.160,00 €	1.332,00 €	1.366,00 €		
<b>3228-1/2"</b>																			
8 mm	ARTE 45.18 A	13,8	6860	4440	3580	2770	1x450	3700	8x350	8x350	2x350	950	1150	380	420,00 €	482,00 €	498,00 €		
	ARTE 45.28 A	27,7	13800	8900	7210	5600	2x450	7400	10x700	10x700	2x700	1600	1150	380	678,00 €	790,00 €	813,00 €		
	ARTE 45.38 A	41,5	23580	16350	12130	9240	3x450	11100	10x1000	10x1000	2x1000	2250	1150	380	933,00 €	1.081,00 €	1.110,00 €		
	ARTE 45.48 A	51,1	28500	18870	14600	11200	4x450	13800	10x1250	10x1250	2x1250	2700	1150	380	1.143,00 €	1.315,00 €	1.349,00 €		
	ARTE 50.18 A	22,7	10240	7160	5420	4120	1x500	5800	10x450	10x450	2x450	1100	1150	380	486,00 €	572,00 €	597,00 €		
	ARTE 50.28 A	45,4	20600	14500	11000	8400	2x500	11600	10x850	10x850	2x850	1900	1150	380	833,00 €	962,00 €	1.000,00 €		
	ARTE 50.38 A	68,1	31000	21700	16600	12620	3x500	17400	10x1250	10x1250	2x1250	2700	1150	380	1.140,00 €	1.312,00 €	1.363,00 €		
	ARTE 50.48 A	90,8	41350	29000	22150	16900	4x500	23200	10x1650	10x1650	2x1650	3500	1150	380	1.412,00 €	1.627,00 €	1.692,00 €		

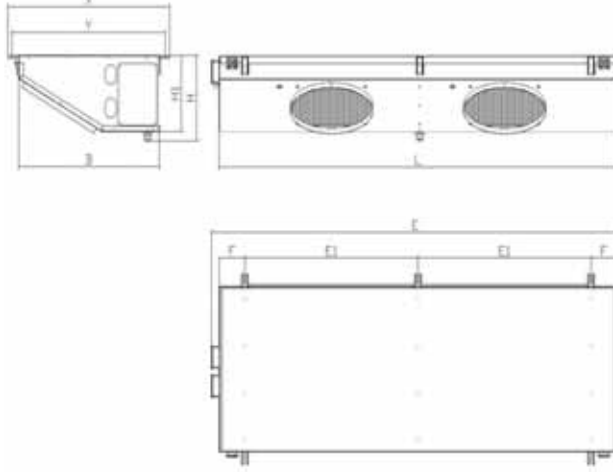

### ARKS SERİSİ KABİN SOĞUTUCULAR ARKS SERIES WALK IN ROOM AIR COLLERS

Lamel Aralığı Fin Spacing	MODEL MODEL	Isı Transfer Alanı Heat Transfer Area	Kapasite Capacity (R 404 A)				Fan Fan		Defrost Isıtıcı Defrost Heater			Boyutlar Dimension			Fiyat Price		
			Watt				Fan Çap Fan Diameter	Hava Debisi Air Flow Rate	E1	E2	Tava Drainer	L	B	H1	Rezistansız Without Resistance	E1 Rezistanslı With E1 Resistance	E2 Rezistanslı With E2 Resistance
			SC1	SC2	SC3	SC4											
			m <sup>2</sup>	Te=0 °C To=+10 °C	Te= -8 °C To=0 °C	Te= -25 °C To=-18 °C	Te= -31 °C To=-25 °C	mm	m <sup>3</sup> /h	Waat	Waat	Waat	mm	mm	mm	€	€
<b>3228-3/8"</b>																	
4 mm Hatve Fin Spacing	ARKS 25.14 A	3,2	945	610	-	-	1x250	480	1x200	-	-	490	500	210	86	90	-
	ARKS 25.24 A	6,4	1920	1220	-	-	2x250	960	2x350	-	-	810	500	210	133	138	-
	ARKS 25.24 B	9,6	2470	1500	-	-	2x250	900	2x350	-	-	810	500	210	158	173	-
	ARKS 25.34 A	9,6	3160	2200	-	-	3x250	1440	2x500	-	-	1090	500	210	170	188	-
	ARKS 25.44 A	12,8	4070	2800	-	-	4x250	1920	2x650	-	-	1390	500	210	206	228	-
	ARKS 30.14 A	8,5	2870	1980	-	-	1x300	1400	2x650	-	-	870	650	275	154	169	-
	ARKS 30.14 B	12,8	3675	2475	-	-	1x300	1210	2x650	-	-	870	650	275	181	196	-
	ARKS 30.24 A	17,0	5760	4000	-	-	2x300	2800	2x650	-	-	1470	650	275	215	236	-
	ARKS 30.24 B	25,5	7620	5370	-	-	2x300	2420	2x650	-	-	1470	650	275	264	286	-
	ARKS 30.34 A	25,5	9010	6280	-	-	3x300	4200	2x1000	-	-	2070	650	275	317	345	-
ARKS 30.34 B	38,3	11500	8100	-	-	3x300	3630	2x1000	-	-	2070	650	275	389	416	-	
ARKS 30.44 A	34,1	11600	8020	-	-	4x300	5600	2x1250	-	-	2670	650	275	405	439	-	
ARKS 30.44 B	51,1	15350	10800	-	-	4x300	4840	2x1250	-	-	2670	650	275	495	529	-	
<b>3228-3/8"</b>																	
6 mm Hatve Fin Spacing	ARKS 25.16 A	2,1	735	490	392	320	1x250	485	1x200	1x200	2x200	490	500	210	89,00 €	95,00 €	107,00 €
	ARKS 25.26 A	4,3	1450	960	785	615	2x250	970	2x350	2x350	2x350	810	500	210	143,00 €	158,00 €	173,00 €
	ARKS 25.26 B	6,4	1925	1265	1040	810	2x250	910	2x350	2x350	2x350	810	500	210	165,00 €	180,00 €	195,00 €
	ARKS 25.36 A	6,4	2650	1765	1350	1055	3x250	1455	2x500	2x500	2x500	1090	500	210	173,00 €	191,00 €	207,00 €
	ARKS 25.46 A	8,5	3480	2260	1765	1375	4x250	1940	2x650	2x650	2x65	1390	500	210	241,00 €	263,00 €	284,00 €
	ARKS 30.16 A	5,7	2380	1600	1250	955	1x300	1465	2x350	2x350	2x350	870	650	275	148,00 €	162,00 €	177,00 €
	ARKS 30.16 B	8,5	3120	2000	1570	1225	1x300	1310	2x350	2x350	2x350	870	650	275	174,00 €	189,00 €	204,00 €
	ARKS 30.26 A	11,4	4780	3190	2500	1935	2x300	2930	2x650	2x650	2x650	1470	650	275	224,00 €	246,00 €	267,00 €
	ARKS 30.26 B	17,0	6615	4560	3390	1625	2x300	2620	2x650	2x650	2x650	1470	650	275	271,00 €	293,00 €	314,00 €
	ARKS 30.36 A	17,0	7730	5330	4020	3100	3x300	4395	2x1000	2x1000	2x1000	2070	650	275	301,00 €	329,00 €	357,00 €
	ARKS 30.36 B	25,5	9960	6850	5125	3980	3x300	3930	2x1000	2x1000	2x1000	2070	650	275	372,00 €	400,00 €	428,00 €
	ARKS 30.46 A	22,7	9570	6400	5000	3880	4x300	5860	2x1250	2x1250	2x1250	2670	650	275	385,00 €	419,00 €	453,00 €
	ARKS 30.46 B	34,1	13300	9150	6850	5300	4x300	5240	2x1250	2x1250	2x1250	2670	650	275	473,00 €	506,00 €	540,00 €
<b>3228-3/8"</b>																	
8 mm Hatve Fin Spacing	ARKS 25.18 A	1,6	615	395	345	270	1x250	490	1x200	1x200	2x200	490	500	210	89,00 €	95,00 €	106,00 €
	ARKS 25.28 A	3,2	1200	810	665	515	2x250	980	2x350	2x350	2x350	810	500	210	142,00 €	157,00 €	172,00 €
	ARKS 25.28 B	4,8	1580	1070	875	680	2x250	930	2x350	2x350	2x350	810	500	210	163,00 €	178,00 €	193,00 €
	ARKS 25.38 A	4,8	2330	1520	1180	910	3x250	1470	2x500	2x500	2x500	1090	500	210	171,00 €	189,00 €	207,00 €
	ARKS 25.48 A	6,4	3020	1915	1545	1180	4x250	1960	2x650	2x650	2x65	1390	500	210	239,00 €	261,00 €	282,00 €
	ARKS 30.18 A	4,3	2010	1300	1030	810	1x300	1520	2x350	2x350	2x350	870	650	275	146,00 €	161,00 €	176,00 €
	ARKS 30.18 B	6,4	2650	1690	1350	1055	1x300	1370	2x350	2x350	2x350	870	650	275	172,00 €	187,00 €	202,00 €
	ARKS 30.28 A	8,5	4020	2630	2085	1620	2x300	3040	2x650	2x650	2x650	1470	650	275	221,00 €	243,00 €	264,00 €
	ARKS 30.28 B	12,8	5860	4005	2975	2305	2x300	2740	2x650	2x650	2x650	1470	650	275	267,00 €	288,00 €	310,00 €
	ARKS 30.38 A	12,8	6650	4620	3440	2650	3x300	4560	2x1000	2x1000	2x1000	2070	650	275	297,00 €	324,00 €	352,00 €
	ARKS 30.38 B	19,2	8800	6040	4500	3500	3x300	4110	2x1000	2x1000	2x1000	2070	650	275	365,00 €	393,00 €	421,00 €
	ARKS 30.48 A	17,0	8040	5230	4175	3240	4x300	6080	2x1250	2x1250	2x1250	2670	650	275	379,00 €	413,00 €	447,00 €
	ARKS 30.48 B	25,5	11750	8050	6000	4660	4x300	5480	2x1250	2x1250	2x1250	2670	650	275	463,00 €	497,00 €	531,00 €

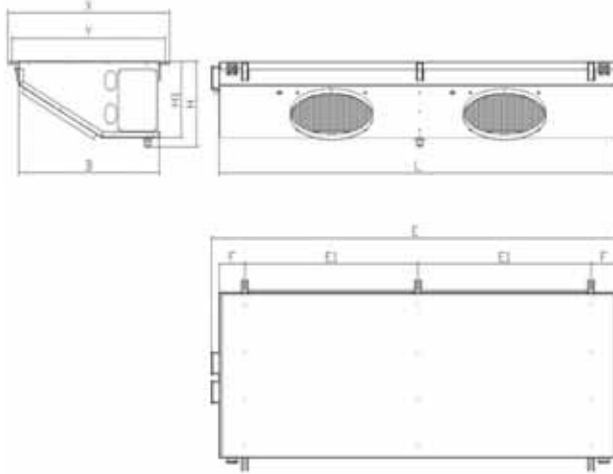

### ARAS SERİSİ KABİN SOĞUTUCULAR ARAS SERIES WALK IN ROOM AIR COLLERS

Lamel Aralığı Fin Spacing	MODEL MODEL	Isı Transfer Alanı Heat Transfer Area	Kapasite Capacity (R 404 A)				Fan Fan		Defrost Isıtıcı Defrost Heater			Boyutlar Dimension			Fiyat Price		
			Watt				Fan Çapı Fan Diameter mm	Hava Debisi Air Flow Rate m <sup>3</sup> /h	E1		E2	L mm	B mm	H1 mm	Rezistansız Without Resistance €	E1 Rezistanslı With E1 Resistance €	E2 Rezistanslı With E2 Resistance €
			SC1	SC2	SC3	SC4			Batarya coil	Batarya coil	Tava Drainer						
			m <sup>2</sup>	Te=0 °C To=+10 °C	Te= - 8 °C To=0 °C	Te= - 25 °C To=-18 °C	Te= - 31 °C To=- 25 °C	Watt	Watt	Watt							

3228-3/8" & Q MOTOR																	
4 mm Hatve/ Fin Spacing	ARKS Q 20.14 A	3,2	785	515	-	-	1x200	340	1x200	-	-	510	500	210	83,00 €	89,00 €	-
	ARKS Q 20.24 A	6,4	1600	1030	-	-	2x200	680	1x350	-	-	810	500	210	130,00 €	138,00 €	-
	ARKS Q 20.34 A	9,6	2700	1870	-	-	3x200	1020	2x500	-	-	1090	500	210	167,00 €	185,00 €	-
	ARKS Q 20.44 A	12,8	3530	2350	-	-	4x200	1360	2x650	-	-	1390	500	210	204,00 €	225,00 €	-
	ARKS Q 25.14 A	3,2	885	515	-	-	1x250	440	1x200	-	-	490	500	210	86,00 €	90,00 €	-
	ARKS Q 25.24 A	6,4	1740	1110	-	-	2x250	880	2x350	-	-	810	500	210	133,00 €	138,00 €	-
	ARKS Q 25.34 A	9,6	2870	1990	-	-	3x250	1320	2x500	-	-	1090	500	210	170,00 €	188,00 €	-
ARKS Q 25.44 A	12,8	3680	2525	-	-	4x250	1760	2x650	-	-	1390	500	210	206,00 €	228,00 €	-	

3228-3/8" & Q MOTOR																	
6 mm Hatve/ Fin Spacing	ARKS Q 20.16 A	2,1	615	415	345	270	1x200	360	1x200	1x200	2x200	510	500	210	81,00 €	87,00 €	98,00 €
	ARKS Q 20.26 A	4,3	1225	835	685	540	2x200	720	1x350	1x350	2x350	810	500	210	130,00 €	137,00 €	152,00 €
	ARKS Q 20.36 A	6,4	2305	1500	1155	910	3x200	1080	2x500	2x500	2x500	1090	500	210	166,00 €	184,00 €	202,00 €
	ARKS Q 20.46 A	8,5	3015	1910	1500	1180	4x200	1440	2x650	2x650	2x650	1390	500	210	202,00 €	224,00 €	245,00 €
	ARKS Q 25.16 A	2,1	685	465	370	295	1x250	470	1x200	1x200	2x200	490	500	210	82,00 €	87,00 €	100,00 €
	ARKS Q 25.26 A	4,3	1375	910	735	590	2x250	940	1x350	1x350	2x350	810	500	210	129,00 €	137,00 €	153,00 €
	ARKS Q 25.36 A	6,4	2525	1690	1275	1005	3x250	1410	2x500	2x500	2x500	1090	500	210	169,00 €	185,00 €	205,00 €
ARKS Q 25.46 A	8,5	3310	2160	1690	1300	4x250	1880	2x650	2x650	2x650	1390	500	210	205,00 €	225,00 €	248,00 €	

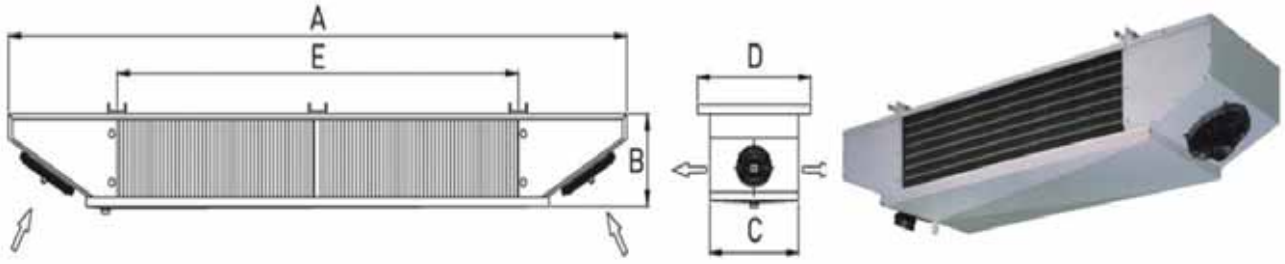

### ARTSD SERİSİ YAVAŞ ÜFLEMELİ TAVAN SOĞUTUCULAR ARTSD SERIES SLOW DISCHARGE AIR COLLERS

Lamel Aralığı Fin Spacing	MODEL MODEL	Isı Transfer Alanı Heat Transfer Area	Kapasite Capacity (R 404 A)				Fan Fan		Defrost Isıtıcı Defrost Heater			Boyutlar Dimension			Fiyat Price				
			Watt				Fan Çapı Fan Diameter	Hava Debisi Air Flow Rate	E1		Tava Drainer	A	B	C	Rezistansız Without Resistance	E1 Rezistanslı With E1 Resistance	E2 Rezistanslı With E2 Resistance		
			SC1	SC2	SC3	SC4			Batarya coil	Batarya coil									
			m <sup>2</sup>	Te=0 °C	To=+10 °C	Te=-8 °C	To=0 °C	To=25 °C	To=-18 °C	To=-31 °C	To=-25 °C	mm	m <sup>3</sup> /h	Waat	Waat	Waat	mm	mm	mm
<b>3228-3/8"</b>																			
4 mm Hatve/ Fin Spacing	ARTSD 20.24	25,7	3200	2450	-	-	2x200	910	2x450	-	-	1700	250	600	348	373	357		
	ARTSD 25.24	51,4	6900	4750	-	-	2x250	1860	2x850	-	-	2500	250	650	547	579	553		
	ARTSD 30.24	77,1	12100	8600	-	-	2x300	3600	4x1250	-	-	3300	250	650	750	834	792		
<b>3228-3/8"</b>																			
6 mm Hatve/ Fin Spacing	ARTSD 20.26	17,6	2900	2250	1705	1350	2x200	940	2x450	2x450	2x450	1700	250	600	338	362	350		
	ARTSD 25.26	35,3	6300	4350	2950	2450	2x250	1900	4x850	4x850	2x850	2500	250	650	521	563	536		
	ARTSD 30.26	52,9	10600	7550	5230	4200	2x300	3680	4x1250	4x1250	2x1250	3300	250	650	730	799	771		
<b>3228-3/8"</b>																			
8 mm Hatve/ Fin Spacing	ARTSD 20.28	13,6	2650	2010	1510	1240	2x200	1020	2x450	2x450	2x450	1700	250	600	336	357	344		
	ARTSD 25.28	27,2	5900	4020	2630	2100	2x250	2050	4x850	4x850	2x850	2500	250	650	510	556	532		
	ARTSD 30.28	40,9	9650	6850	4840	3890	2x300	3740	4x1250	4x1250	2x1250	3300	250	650	718	788	761		

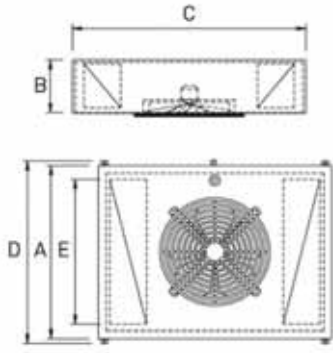

### ARTS SERİSİ TAVAN SOĞUTUCULAR ARTS SERIES AIR COLLERS

Lamel Aralığı Fin Spacing	MODEL MODEL	Isı Transfer Alanı Heat Transfer Area	Kapasite Capacity (R 404 A)		Fan Çapı Fan Diameter	Boyutlar Dimension			Fiyat Price
			Watt			A	B	C	
			SC1	SC2					
			m <sup>2</sup>	Te=0 °C To=+10 °C Te=-8 °C To=0 °C		mm	mm	mm	
<b>3228-3/8"</b>									
5 mm Hatve/ Fin Spacing	ARTS 20.15	3,2	675	490	1x200	400	150	550	133,00 €
	ARTS 25.15	5,6	1350	990	1x250	450	150	700	178,00 €
	ARTS 25.25	5,6	1750	1250	2x250	450	150	1050	243,00 €
	ARTS 30.15	6,5	2100	1600	1x300	500	150	750	205,00 €
	ARTS 30.25	6,5	2700	2000	2x300	500	150	1200	266,00 €

### ARKYS & ARKOS SERİSİ KABİNLİ YAN SOĞUTUCULAR ARKYS & ARKOS SERIES SIDE GRAVITY COLLERS FOR WINDOWS

Lamel Aralığı Fin Spacing	MODEL MODEL	Isı Transfer Alanı Heat Transfer Area	Kapasite Capacity (R 404 A)		(Kare) Fan Çapı Fan Diameter	Boyutlar Dimension			Fiyat Price
			Watt			a	b	c	Ral 7035
			Kcal/h	mm					
			m <sup>2</sup>	mm		mm	mm	mm	€
<b>3228-3/8"</b>									
4 mm Hatve/ Fin Spacing	ARKYS 12.02 A	2,6	239	205	Ø 120	400	130	530	87,00 €
	ARKYS 12.02 B	3,5	436	375	Ø 120	400	130	590	93,00 €
	ARKOS 12.02 A	2,6	239	205	Ø 120	400	130	530	87,00 €
	ARKOS 12.02 B	3,5	436	375	Ø 120	400	130	590	93,00 €

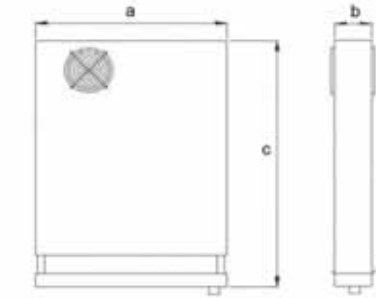

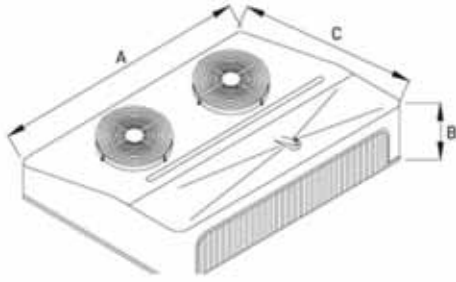

**ARTEP SERİSİ PLASTİK KABİNLİ TAVAN SOĞUTUCULAR**  
ARTEP SERIES AIR COLLERS

Lamel Aralığı Fin Spacing	MODEL MODEL	Isı Transfer Alanı Heat Transfer Area	Kapasite Capacity (R 404 A)		Fan Sayısı Number of Fans	Fan Çapı Fan Diameter	Boyutlar Dimension			Fiyat Price
			Wat	Kcal h			A	B	C	
		m <sup>2</sup>			n	mm	mm	mm	mm	€
<b>3228-3/8"</b>										
4 mm Hatve Fin Spacing	ARTEP 20.01 A	3,2	950	816	1	200	465	145	435	109,00 €
	ARTEP 20.01 B	3,1	800	687	1	200	455	145	445	100,00 €
	ARTEP 20.02 A	5,0	1600	1374	2	200	730	145	445	159,00 €
	ARTEP 20.03 A	7,1	1900	1632	3	200	1030	145	445	220,00 €
	ARTEP 30.01 A	5,7	1500	1289	1	300	785	145	475	171,00 €

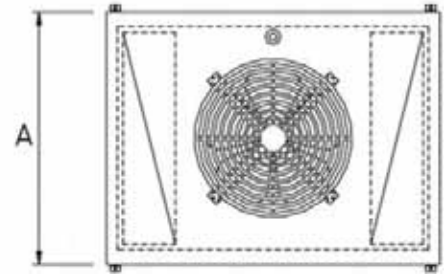
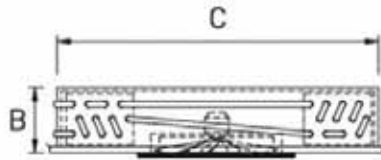
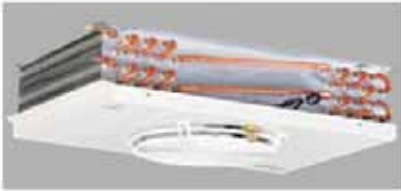

**KARAMAN SOĞUTUCULARI**  
KARAMAN AIR COLLERS

Lamel Aralığı Fin Spacing	MODEL MODEL	Isı Transfer Alanı Heat Transfer Area	Kapasite Capacity (R 404 A)		Fan Sayısı Number of Fans	Fan Çapı Fan Diameter	Boyutlar Dimension			Fiyat Price	
			SC1	SC2			A	B	C		
		m <sup>2</sup>	Te=0 °C	To=+10 °C	Te=-8 °C	To=0 °C	n	mm	mm	mm	mm
<b>3228-1/2"</b>											
6 mm Hatve Fin Spacing	KARAMAN UFAK	3,8	1000	750	1	250	415	160	700	113,00 €	
	KARAMAN ORTA	5,7	1250	900	1	250	415	185	700	145,00 €	
	KARAMAN BÜYÜK	8,5	1500	1100	2	250	415	185	800	174,00 €	
	KARAMAN 2 FAN	9,6	2500	1850	2	250	470	185	1100	227,00 €	



 **ARAS**   
**SOĞUTMA**  
**AYAKKABI GIDA OTO. SAN.TİC.LTD.ŞTİ**



OHSAS 18011: 2007



TS EN ISO 9001: 2008

Kirazlı Mah. Mevlana Cad. Enes Sok. No: 43 (Tavukçu Köprü Cad. Emin İş Merkezi Arka Kapısı) Bağcılar / İSTANBUL

**Tel: +90 212 430 42 52 Faks: +90 212 430 42 53**

e-mail 1: araskondanserevaporator@gmail.com e-mail 2 : info@araskondenser.com

web: www.araskondenser.com